

STATES OF JERSEY



DRAFT SEA FISHERIES (TRAWLING, NETTING AND DREDGING) (AMENDMENT No. 3) (JERSEY) REGULATIONS 201-

**Lodged au Greffe on 17th August 2010
by the Minister for Economic Development**

STATES GREFFE



Jersey

DRAFT SEA FISHERIES (TRAWLING, NETTING AND DREDGING) (AMENDMENT No. 3) (JERSEY) REGULATIONS 201-

REPORT

The scallop fishery in local waters is of significant importance to local and French fishermen, with Jersey vessels landing over 350 tonnes of scallops in 2009. The traditional vessels working in the fishery tow a limited number of dredges attached to relatively light equipment, but in the past larger vessels have operated heavier equipment with more dredges. As no such vessels are currently licensed to operate in the fishery, fishermen have recommended that restrictions be introduced to limit the number of dredges that may be towed, effectively restricting the fishery to smaller, locally-based French and Jersey fishing boats. The restriction in the weight and size of equipment towed over the seabed will also serve to protect the marine environment.

The size of mesh that may be used in both trawls and static nets is already regulated, and relates to the species that may be caught using such a net. Mesh sizes are set to allow the escape of juvenile fish and it is therefore important that Fishery Officers, net manufacturers and fishermen have a reliable, objective method of accurately measuring the mesh size. Until 1st September 2009, the designated method throughout Europe involved the use of a wedge-shaped gauge, pressure being applied manually. Following many years of research and consultation with the industry, the Omega electronic gauge was produced and became the designated device for mesh measurement from 1st September 2009. The Omega gauge applies a measured force and automatically records the measurements, calculating an average mesh size. This amendment will bring Jersey into line with the rest of Europe and is necessary under the terms of the Jersey/UK Fisheries management Agreement.

Experience has shown that the Omega gauge often records a smaller measurement in respect of well-used trawls than the previous wedge gauge produced. This is not a fault of the gauge, but ensures that the scientifically calculated mesh sizes can be enforced throughout the life of a trawl. This disparity does, however, need to be recognised and, in accordance with the policy adopted by other jurisdictions, Jersey Fishery Officers will for 3 months after the amendment is enacted, use the gauge in an advisory manner. Where during that period mesh size is found to contravene the Regulations, fishermen will be given the opportunity to change the appropriate piece of netting without being subject to any enforcement process, unless the mesh size would have also failed measurement using the old-style wedge gauge.

Advantage has been taken of this amendment to rectify an oversight in the existing legislation whereby a traditional hand-pushed prawn net needed to comply with the Regulations applicable to a full-size trawl.

Financial and manpower implications

There are no financial or manpower implications arising from the adoption of these Draft Regulations.

Explanatory Note

These Regulations amend the Sea Fisheries (Trawling, Netting and Dredging) (Jersey) Regulations 2001 to bring them into line with the EU standards for measuring the mesh size and twine thickness of fishing nets.



Jersey

**DRAFT SEA FISHERIES (TRAWLING, NETTING
AND DREDGING) (AMENDMENT No. 3) (JERSEY)
REGULATIONS 201-**

Arrangement

Regulation

1	Interpretation	9
2	Regulation 1 amended.....	9
3	Regulation 26B amended	9
4	Parts 3, 4 and 4A substituted.....	10
5	Schedules 6, 7 and 8 substituted.....	16
6	Citation.....	28
7	Commencement.....	28



Jersey

DRAFT SEA FISHERIES (TRAWLING, NETTING AND DREDGING) (AMENDMENT No. 3) (JERSEY) REGULATIONS 201-

Made [date to be inserted]

Coming into force [date to be inserted]

THE STATES, in pursuance of Articles 2, 5, 7, 8 and 29 of the Sea Fisheries (Jersey) Law 1994¹, having consulted with the Secretary of State and obtained his concurrence, have made the following Regulations –

1 Interpretation

In these Regulations “the principal Regulations” means the Sea Fisheries (Trawling, Netting and Dredging) (Jersey) Regulations 2001².

2 Regulation 1 amended

In Regulation 1 of the principal Regulations –

(a) for the definition “mesh size” there is substituted the following definition –

“ ‘mesh size’ has the meaning given to that expression by Regulation 27;”;

(b) for the definition “passive gear” there is substituted the following definition –

“ ‘passive gear’ has the meaning given to that expression by Regulation 27;”.

3 Regulation 26B amended

Regulation 26B of the principal Regulations is amended by adding the following paragraphs –

“(3) It is prohibited for a fishing boat to use more than 16 scallop dredges at any one time.

- (4) It is prohibited to use a number of scallop dredges at any one time with aggregate mouth sizes that exceed 12.8 metres.
- (5) It is prohibited to carry on board a fishing boat a number of scallop dredges with aggregate mouth sizes that exceed 12.8 metres unless the dredges that would cause that size to be exceeded are stowed in a way in which they may not readily be used.”.

4 **Parts 3, 4 and 4A substituted**

For Parts 3, 4 and 4A of the principal Regulations there is substituted the following Part –

“PART 3

DETERMINING MESH SIZE AND ASSESSING TWINE THICKNESS OF FISHING GEAR

Chapter 1 – Interpretation

27 Interpretation – Part 3

In this Part –

‘active gear’ means fishing gear for which the catch operation requires an active movement of the gear, and includes –

- (a) towed gear;
- (b) encircling gear;
- (c) a trawl;
- (d) a Danish seine; and
- (e) any similar towed net,

but does not include a net that is operated by being pushed by hand by an individual who is walking or standing on the seabed;

‘diamond mesh’ means a mesh as shown in figure 1 of Schedule 7, composed of 4 bars of the same length where the 2 diagonals of the mesh are perpendicular and one diagonal is parallel to the longitudinal axis of the net as shown in figure 2 of Schedule 7;

‘mesh gauge’ means a mesh measuring gauge that has 2 jaws that automatically apply longitudinal forces in the range of 5 to 180 Newton to a mesh, with a precision of 1 Newton;

‘mesh size’ means –

- (a) in respect of a mesh of knotted netting, the longest distance between 2 opposite knots in the same mesh when fully extended as shown in Schedule 6;

- (b) in respect of a mesh of knotless netting, the inside distance between the opposite joints in the same mesh when fully extended along its longest possible axis;

‘N-direction’, in respect of knotted netting, means the direction at right angles to the general course of the netting yarn, as shown in Schedule 6;

‘passive gear’ means fishing gear for which the catch operation does not require an active movement of the gear, and includes –

- (a) a gillnet;
- (b) an entangling net;
- (c) a trammel net; and
- (d) a trapnet;

‘T-direction’ means –

- (a) in respect of knotted netting, the direction parallel to the general course of the netting yarn, as shown in Schedule 6;
- (b) in respect of knotless netting, the direction at right angles to the N-direction;

‘square mesh’ means a quadrilateral mesh composed of 2 sets of parallel bars of the same length, where 1 set is parallel to, and the other is at right angles to, the longitudinal axis of the net;

‘T90 mesh’ means a diamond mesh from knotted netting, as shown in figure 1 of Schedule 7, mounted so that the T-direction of the netting is parallel to the longitudinal axis of the net.

Chapter 2 – EC gauges

28 Mesh gauge and thickness gauge

A fishery officer, when conducting a fishery inspection of fishing gear, must –

- (a) to determine the mesh size of the gear, use a mesh gauge that complies with the technical specifications set out in Schedule 8; or
- (b) to assess the twine thickness of the gear, use a twine thickness gauge that complies with the technical specifications set out in Schedule 9.

29 Calibration instruments for a mesh gauge

The calibrated test weights and calibrated test measuring plate provided for in figure 1 of Schedule 10 must be certified by the Chief Inspector of Weights and Measures appointed under Article 2 of the Weights and Measures (Jersey) Law 1967³.

30 Testing of a mesh gauge

The accuracy of a mesh gauge must be verified by –

- (a) inserting the jaws of the gauge into slots of the calibrated test plate as provided for in figure 1 of Schedule 10; and
- (b) hanging the calibrated test weights on the fixed jaw, as provided for in figure 2 of Schedule 10.

Chapter 3 – Determination of mesh size

31 Selection of meshes in active gear

- (1) A fishery officer, when conducting a fishery inspection of the mesh size of active gear, must select a series of 20 consecutive meshes from the gear for testing.
- (2) The meshes must be chosen –
 - (a) in the case of diamond and square meshes, in the direction of the longitudinal axis of the gear; and
 - (b) in the case of T90 meshes, perpendicular to the direction of the longitudinal axis of the gear.
- (3) The fisheries officer must not select meshes that are less than 3 meshes from the selvedge, lacings, ropes or cod line when that distance is measured perpendicular to the lacings, ropes or cod line with the net stretched in the direction of that measurement.
- (4) A fisheries officer must not measure a mesh –
 - (a) that is broken or has been repaired; or
 - (b) that has attachments to the net fixed at the mesh.
- (5) Despite paragraph (1), the meshes to be measured need not be consecutive to the extent that the application of paragraph (3) prevents it.

32 Selection of meshes in passive gear

- (1) A fishery officer, when conducting a fishery inspection of the mesh size of passive gear, must select 20 meshes from the gear for testing.
- (2) If there are different mesh sizes in the gear, the meshes must be selected from the part of the gear that has the smallest meshes.
- (3) A fisheries officer must not select meshes –
 - (a) that are at the top, bottom or side of a net selvedge;
 - (b) that are within 3 meshes of lacings or ropes; or
 - (c) that are broken or have been repaired.

33 The preparation and operation of mesh gauges

A fisheries officer, when carrying out a fisheries inspection of the mesh size of fishing gear, must –

- (a) prepare, in accordance with Schedule 11, the mesh gauge to be used; and
- (b) operate the gauge in accordance with Schedule 12.

34 Operation of the mesh gauge for measuring diamond and T90 meshes

- (1) This Regulation specifies how a fisheries officer must measure a diamond or T90 mesh.
- (2) In knotless netting when the N-direction cannot be determined, the officer must measure the longest axis of the mesh.
- (3) In other cases, the netting must be stretched in the N-direction of the meshes and the officer must measure the mesh as shown in Schedule 12.

35 Operation of the mesh gauge for measuring square meshes

- (1) This Regulation specifies how a fisheries officer must measure a square mesh panel.
- (2) The netting must be stretched first in one diagonal direction and then in the other diagonal direction of the mesh, as shown in Schedule 13.
- (3) The officer must then follow the procedure laid down in Schedule 11 to measure each diagonal direction of the square mesh.

36 Measurement conditions

A fisheries officer, when carrying out a fisheries inspection of the mesh size of fishing gear must measure a mesh when it is wet and not frozen.

37 Measurement of the size of each selected mesh

- (1) For the purposes of a fishing inspection of the meshes of fishing gear, the size of each mesh is the distance between the outside edges of the jaws of the mesh gauge at the point where its movable jaw is stopped.
- (2) However, if there is a difference in measurement between the diagonals of an individual square mesh, the larger diagonal is to be used.

37A Determination of the mesh size of a net

For the purposes of a fishing inspection of the mesh size of fishing gear, the mesh size of the gear is the mean value, as displayed by the gauge, of the series of 20 selected meshes of the gear.

37B Determination of the mesh size in case of disputes

- (1) This Regulation applies if the master of a fishing boat disputes the mesh size of any fishing gear on the boat as determined under Article 37A.
- (2) The fishing officer must select and measure, in accordance with Articles 31 to 37, 20 meshes in another part of the gear.
- (3) The mesh size of the gear is the mean value, displayed by the mesh gauge, of all the 40 meshes measured.
- (4) For the purpose of this Regulation, the displayed result of the mesh gauge is final.

Chapter 4 – Assessing twine thickness

37C General provisions on the selection of twines

- (1) A fishery officer, when testing the thickness of the twine of fishing gear as part of a fishery inspection of the gear, must select meshes from a part of the gear that is subject to a maximum permitted twine thickness.
- (2) The officer must not select a twine from a mesh that is broken or has been repaired.

37D Selection of twine in diamond mesh netting

- (1) If the fishing gear to be tested has diamond mesh netting, the fisheries officer must select the twines to be tested in accordance with paragraph (2).
- (2) In the case of –
 - (a) single twine netting, the twine on the opposite sides of 10 meshes must be selected; or
 - (b) double twine netting, each strand of twine on opposite sides of 5 meshes must be selected,as shown by Schedule 13.

37E Selection of twines in square mesh netting

- (1) If the fishing gear to be tested has square mesh, the fisheries officer must select the twines to be tested in accordance with paragraph (2).

- (2) In the case of –
- (a) single twine netting, the twine on one side of 20 meshes must be selected, with the same side being selected in each mesh; or
 - (b) double twine netting, each strand of twine on one side of 10 meshes must be assessed, with the same side being selected in each mesh,
- as shown by Schedule 13.

37F Selection of the twine thickness gauge

A fisheries officer, to test the thickness of twine in fishing gear as part of a fishery inspection, must use a gauge that has a circular hole with a diameter equal to the maximum twine thickness permitted for the part of the gear to be considered.

37G Assessment conditions

A fisheries officer, when conducting a fishery inspection of fishing gear as part of a fishery inspection, must not test the thickness of a twine in the gear when the twine is frozen.

37H Assessment of the thickness of each selected twine

A fisheries officer, when testing the thickness of a twine in fishing gear as part of a fishery inspection of the gear, must note the twine as a negative if –

- (a) the thickness of the twine prevents the closure of the jaws of the gauge; or
- (b) the twine does not pass easily through the hole when the jaws are closed.

37I Assessing twine thickness

- (1) This Regulation applies if a fisheries officer notes more than 5 negative assessments of the 20 twines selected under Regulation 37C.
- (2) The fisheries officer must select and assess a further 20 twines in accordance with Regulations 37C to 37H.
- (3) If the fisheries officer notes more than 10 negative of the total 40 twines selected the twine thickness is to be taken to have exceeded the maximum twine thickness permitted for that part of the fishing gear.

37J Assessment of twine thickness in case of disputes

- (1) This Regulation applies if the master of a fishing boat disputes the twine thickness of any fishing gear on the boat as assessed under Article 37I.
- (2) The fisheries officer must select and assess 20 different twines in the same part of the fishing gear.
- (3) If more than 5 negative assessments of the total 20 twines selected are noted, the twine thickness is to be taken as exceeding the maximum twine thickness permitted for that part of the fishing gear.
- (4) For the purpose of this Regulation, that assessment is final.”.

5 Schedules 6, 7 and 8 substituted

For Schedules 6, 7 and 8 of the principal Regulations, there are substituted the following Schedules –

“SCHEDULE 6

(Regulation 27)

**MESH SIZE AND N-DIRECTION AND T-DIRECTION OF NETTING
TWINE**

Figure

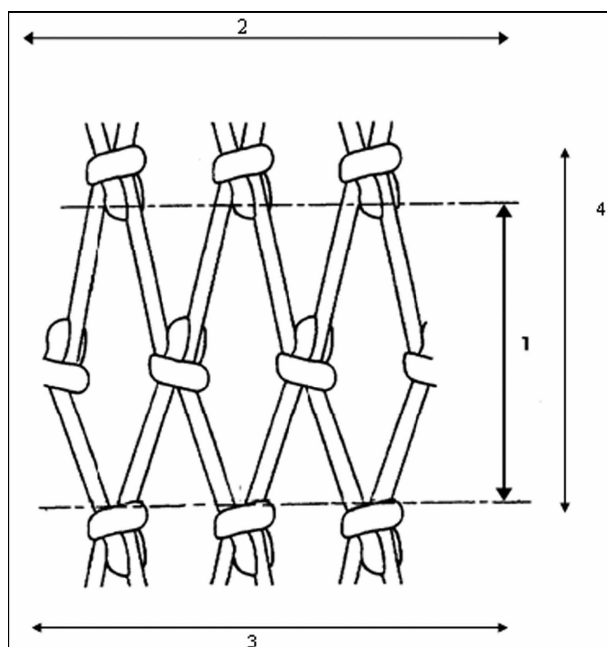

1. Size of mesh.
2. T-direction.
3. General course of the netting.
4. N-direction.

SCHEDULE 7

(Regulation 27)

DIAMOND KNOTTED NETTING AND T90 NETTING

Figure 1

The direction of run of the netting twine in a standard diamond knotted net (A) and in a net turned 90° (B) is shown below.

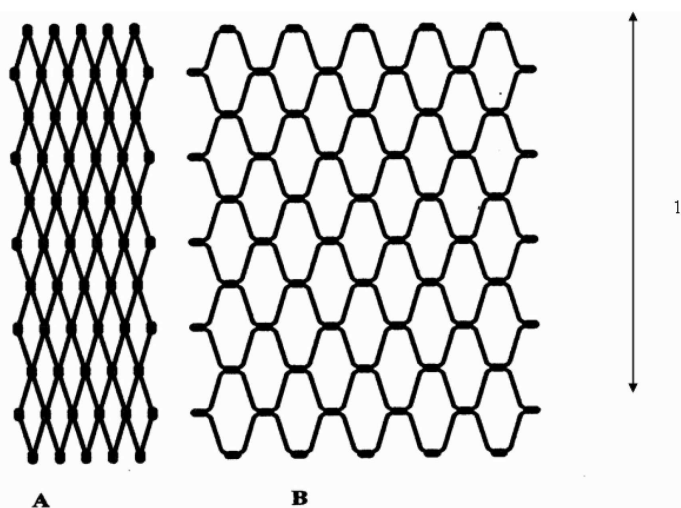

- A. Standard diamond mesh netting.
- B. T90 mesh netting.
- 1. longitudinal axis of the net.

LONGITUDINAL AXIS OF THE NET

Figure 2

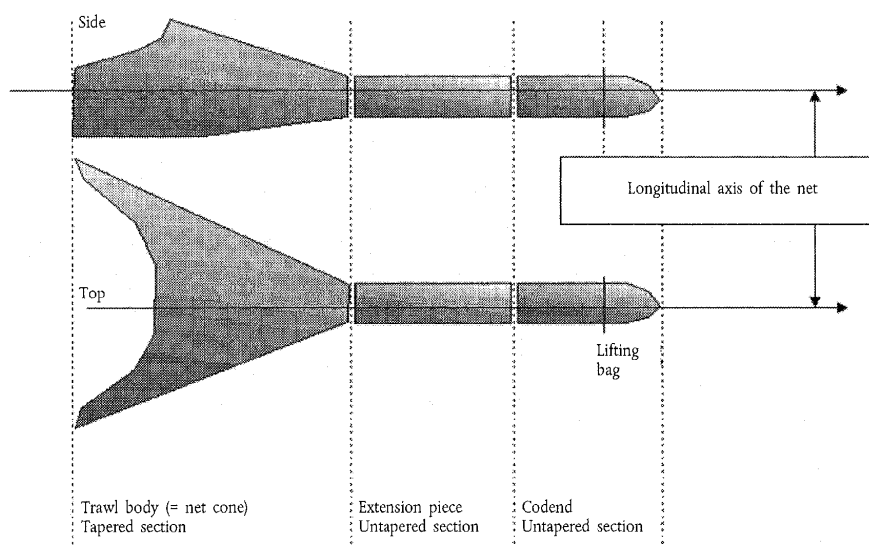

SCHEDULE 8

(Regulation 28)

TECHNICAL SPECIFICATIONS OF THE MESH GAUGE

1. The mesh gauge must –
 - (a) automatically apply a longitudinal measuring force when measuring the mesh size of fishing nets;
 - (b) have 2 jaws, 1 fixed and 1 movable, each 2 mm thick with rounded edges with a radius of 1 mm to ensure that the jaws slip easily over the twine as shown in the figure below;
 - (c) be electrically driven or, if battery powered, must be capable of making 1,000 consecutive mesh measurements before requiring to be recharged;
 - (d) be able to apply selected longitudinal forces, in the range 5 to 180 N, to the meshes with a precision of 1 N;
 - (e) have a built-in system for measuring the applied force;
 - (f) be capable of stretching a mesh at a constant speed of 300 ± 30 mm/min by the movable jaw;
 - (g) be able to measure meshes from 10 to 300 mm and have detachable jaws for use on small and large meshes;
 - (h) have a measurement precision of 1 mm;
 - (i) have a structure that is rigid and will not distort under load;
 - (j) be light yet robust and must not weigh more than 2.5 kg;
 - (k) be made of materials resistant to corrosion under marine conditions;
 - (l) be water resistant and unaffected by dust to standard IP56(*);
 - (m) be stable in operation over a temperature range of -10° to $+45^{\circ}\text{C}$;
 - (n) be able to withstand temperatures between -30° and $+70^{\circ}\text{C}$ during storage and transportation;
 - (o) be controlled by software that must provide a menu of functions and enable the gauge to self-test the electronic and mechanical parts when started;
 - (p) have a display that shows that the gauge is ready for use and, if it is not, display an error message and then close down and cease operating;
 - (q) be capable of operating with 1 hand and have functions that can be accessed via external buttons;

- (r) show data on an integral display and present each measurement, the number of measurements made in a series, and the mean value in millimetres;
 - (s) be capable of storing the data of at least 1,000 measurements in its memory and be capable of transmitting data to a computer;
 - (t) contain a function to calculate the mean mesh size rounded to the nearest 0.1 mm;
 - (u) incorporate software that has a function that automatically selects the largest diagonal of each mesh to calculate the mean mesh size of square mesh netting; and
 - (v) be capable of saving the data of all measurements made.
2. Some netting creeps under load. The gauge must be capable of responding to this condition by reapplying the fixed force, requiring an algorithm in the controlling software, as described in the Appendix.

(*) International protection (IP) codes are specified in the international standard of the International Electrotechnical Commission (IEC) 60529.

Figure

(These drawings are for illustrative purposes only)

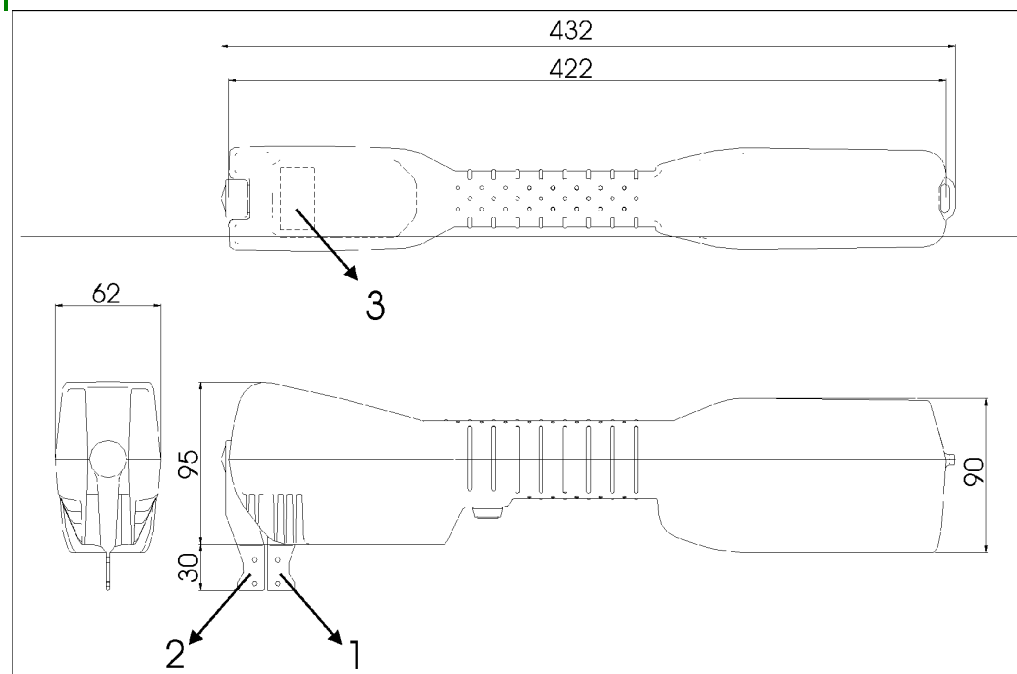

Description	
1	Fixed jaw with load cell
2	Movable jaw
3	Display

Specifications	
Length measurement	
Range:	10-300 mm
Accuracy:	± 1 mm
Force measurement	
Range:	5-180 N
Precision:	± 1 N
Fixed measuring forces:	10 N, 20 N, 50 N, 125 N
Speed movable jaw:	300 ± 30 mm/min(*)
Battery autonomy:	minimum 1,000 measurements
Data storage	
Memory:	minimum 1,000 measurements
Temperature range	
Operating:	- 10° to +40°C
Storage:	- 30° to +70°C
Waterproof	to standard IP56
Shockproof	
Weight	maximum 2.5 kg

(*) Speed of the movable jaw during the stretching of the mesh. The unloaded speed of the movable jaw can be higher.

Appendix to Schedule 8

Measurement algorithm

To allow for creep in a stretched mesh –

1. extend the movable jaw into the mesh at a constant speed of 300 ± 30 mm/min (*), until the measurement force is reached;
2. stop the motor and wait for 1 second;
3. if the force drops below 80% of the pre-set measurement force, extend the movable jaw into the mesh until the measurement force is reached once more.

(*) Speed of the movable jaw during the stretching of the mesh. The unloaded speed of the movable jaw can be higher.

SCHEDULE 9

(Regulation 28)

TECHNICAL SPECIFICATION OF THE TWINE THICKNESS GAUGE

Gauges for assessing the thickness of twine must –

- (a) be made of durable, non-corrosive material able to withstand a harsh marine environment and must be manufactured in accordance with the drawings shown in the figure below;

- (b) have edges around the circumference of each side of the circular hole for assessing the thickness of the twine (the hole) rounded to avoid abrasion when the twine is pulled through the hole to test legality;
- (c) be constructed with the nose of the pliers rounded to facilitate inserting the jaws between double twines;
- (d) have jaws with parallel action that are sufficiently strong to prevent deformation of the jaws during any reasonable use, bearing in mind that the jaws have to be squeezed closed with manual force during every measurement;
- (e) have the inside faces of the jaws milled to leave a 0.5 mm gap for a distance of 1 mm either side of the hole when the jaws are closed in order to avoid single filaments of material protruding from braided or twisted construction being trapped in the flat surfaces of the jaws on each side of the hole in which the twine is seated;
- (f) have, when the jaws are closed, the diameter of the circular hole marked in millimetres on one of the jaws, adjacent to the hole; the jaws are closed when the surface of both internal sides of the jaws touch each other and are flush;
- (g) have a tolerance for the hole diameter of $0 + 0.1$ mm;
- (h) be conveniently portable such that a set of 4 (4 mm, 5 mm, 6 mm, and 8 mm) gauges may be carried by a fisheries officer during vessel to vessel transfer at sea;
- (i) if gauges are of different sizes, be easily identifiable;
- (j) be easy to insert between double twine. After the gauge has been inserted into position, it must be capable of easy operation with 1 hand.

Figure

Twine-measuring pliers assembly

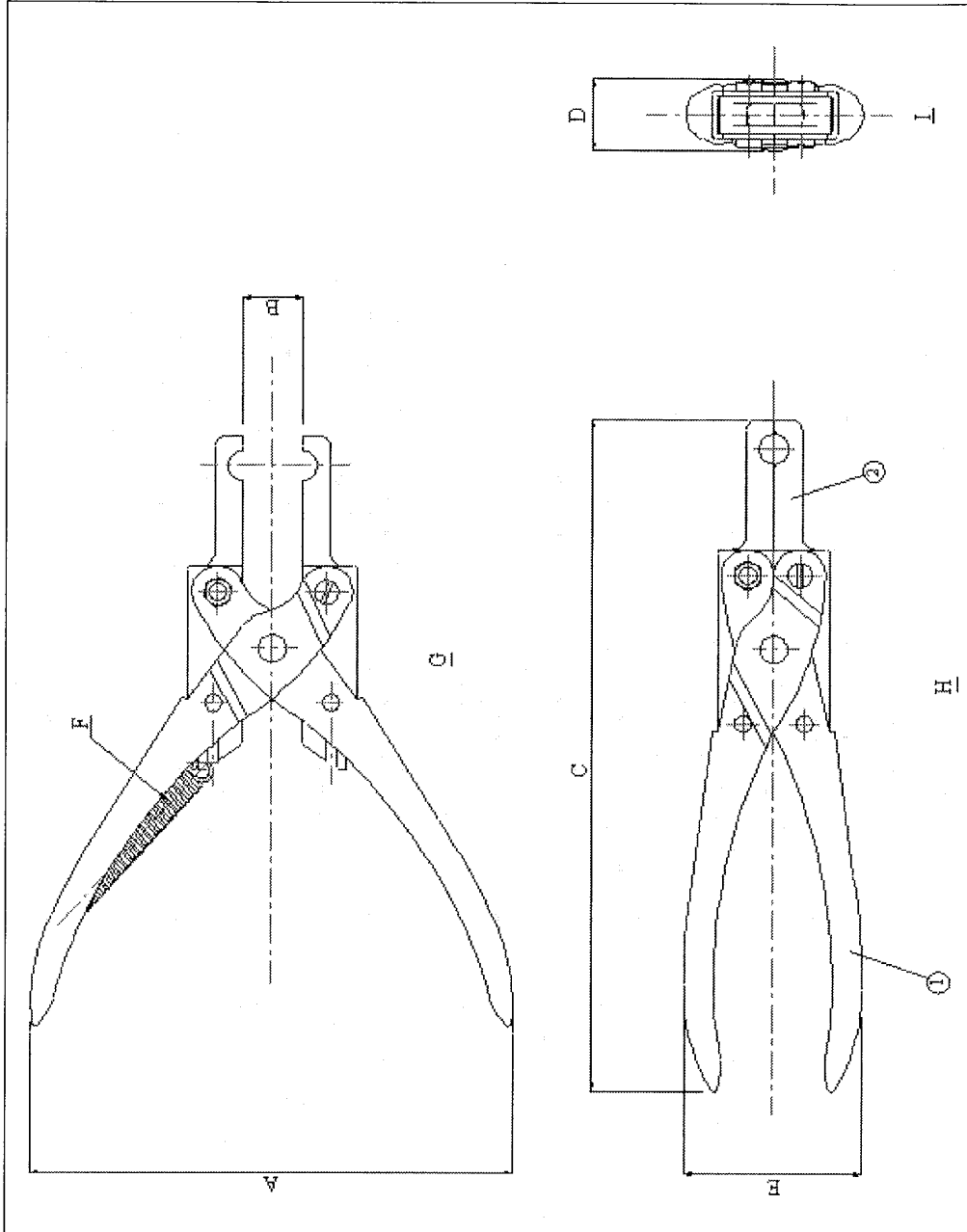

Dimensions and text on drawing	
A	132
B	16
C	161
D	19
E	48
F	In the unused condition the pliers are held open by a tension spring
G	Plan view
H	Front elevation
I	End elevation
1	Handle
2	Jaws

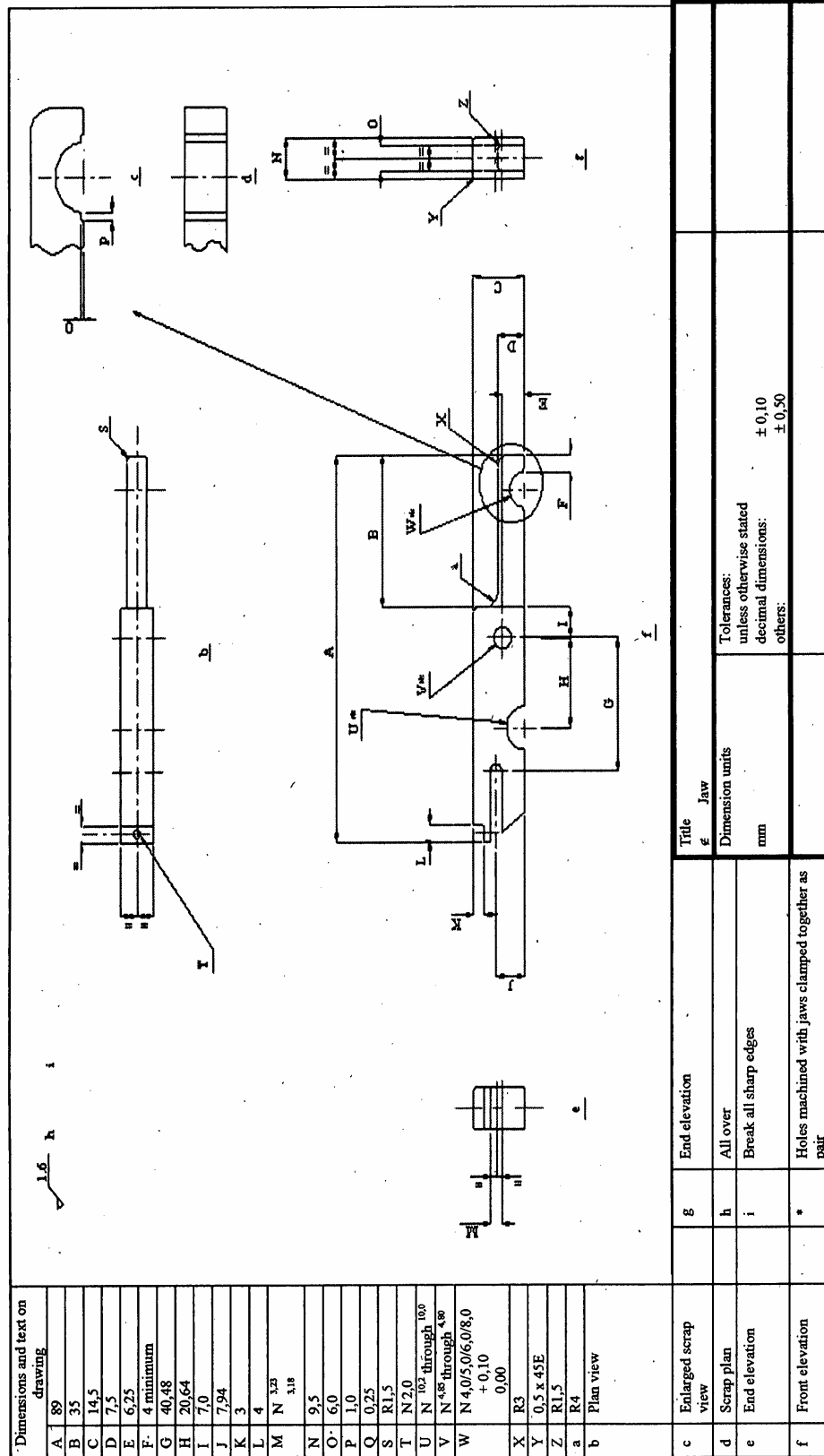

Dimensions and text on drawing		Title	
A	89	g	End elevation
B	35	h	All over
C	14,5	i	Break all sharp edges
D	7,5	*	Holes machined with jaws clamped together as pair
E	6,25		
F	4 minimum		
G	40,48		
H	20,64		
I	7,0		
J	7,94		
K	3		
L	4		
M	N 3,2		
N	N 3,18		
O	N 9,5		
P	6,0		
Q	I,0		
R	0,25		
S	R1,5		
T	N 2,0		
U	N 100 through 100		
V	N 4,58 through 4,58		
W	N 4,0/5,0/6,0/8,0 + 0,10 0,00		
X	R3		
Y	0,5 x 45E		
Z	R1,5		
a	R4		
b	Plan view		
c	Enlarged scrap view		
d	Scrap plan		
e	End elevation		
f	Front elevation		

Tolerances:
 unless otherwise stated
 decimal dimensions: ± 0,10
 others: ± 0,50

SCHEDULE 10

(Regulations 29 and 30)

CALIBRATION AND TESTING OF THE MESH GAUGE**A. Verification of length measurement**

The verification of length measurement must be performed by inserting the jaws of the gauge to be used during the inspection, into slots of different lengths in the calibrated rigid test plate. This can be done at any time.

Figure 1

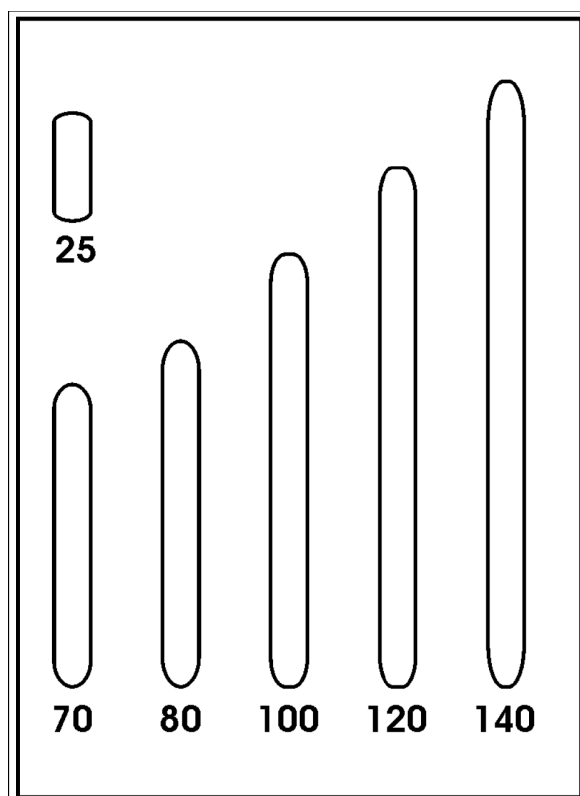

Length of slots in mm

B. Verification of force measurement

The verification of force measurement must be performed by hanging calibrated weights on the fixed jaw containing the load cell, with the gauge held vertical and secure. The weights must have the following values: 10, 20, 50 and 125 N. The weights must only be used under stable conditions.

Figure 2

(This drawing is for illustrative purposes only)

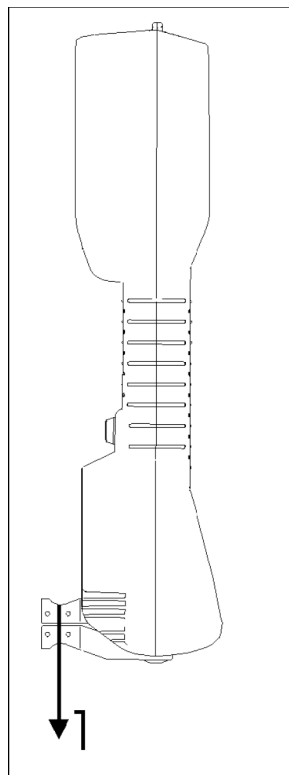

1. Test weight

SCHEDULE 11

(Regulations 33 and 35)

PREPARATION OF THE MESH GAUGE

1. The fisheries officer must –
 - (a) select the appropriate size of jaw for the meshes to be measured;
 - (b) ensure that the jaws are clean;
 - (c) check that the gauge completes the self-test satisfactorily;
 - (d) select the measuring force to be applied as follows –
 - (i) for active gear –
 - 20 N for mesh sizes < 35 mm,
 - 50 N for mesh sizes \geq 35 mm and < 55 mm,

- 125 N for mesh sizes ≥ 55 mm;
 - (ii) for passive gear –
 - 10 N for all mesh sizes;
 - (e) verify the jaw type setting. The default setting is 'Normal'. If small or large jaws are used, the fisheries officer must enter the menu and change the jaw type setting accordingly.
- 2. When the activities set out in paragraph 1 are completed the gauge is ready to undertake mesh measurements.

SCHEDULE 12

(Regulations 33 and 34)

OPERATION OF THE MESH GAUGE FOR INSPECTION

When measuring the meshes the fisheries officer must –

- (a) insert the jaws into the mesh opening with the fixed jaw of the gauge against the knot, as shown in the figure below;
- (b) activate the gauge allowing the jaws to open until the movable jaw reaches the opposite knot and stops when the set force is reached:

Figure

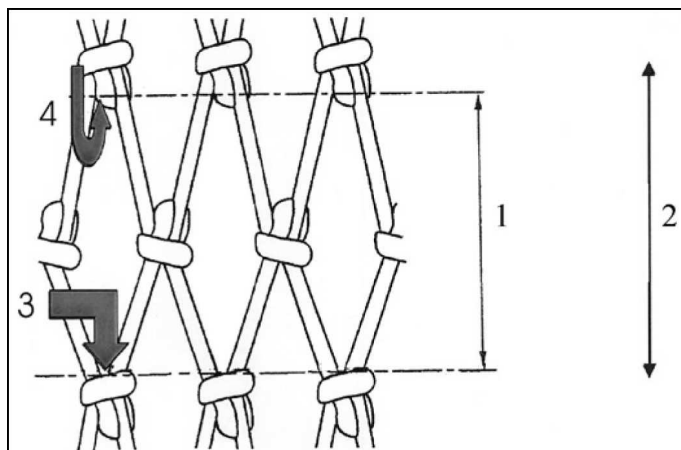

- 1. Mesh size.
- 2. N-direction.
- 3. Fixed jaw.
- 4. Movable jaw.

SCHEDULE 13

(Regulations 35, 37D and 37E)

TWINES IN DIAMOND AND SQUARE MESH NETTING

Figure

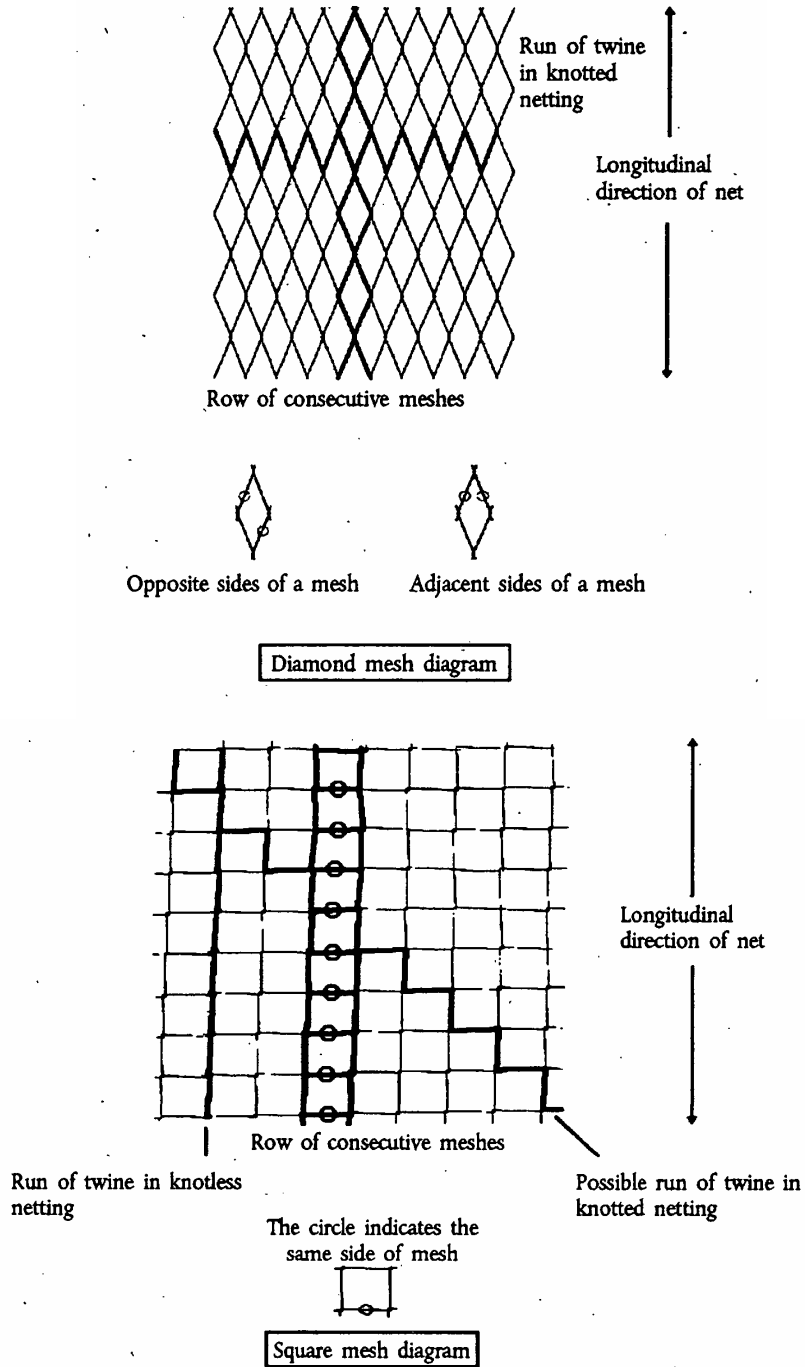

6 Citation

These Regulations may be cited as the Sea Fisheries (Trawling, Netting and Dredging) (Amendment No. 3) (Jersey) Regulations 201-.

7 Commencement

These Regulations come into force 7 days after they are made.

-
- ¹ *chapter 14.825*
² *chapter 14.825.88*
³ *chapter 05.925*