

W.M. PRISON LA MOYE

**D & A
Services**

**Probation
Services**

**Healthcare
Unit**

Psychologist

**Teresa
Rodrigues**

**Staff
Officer**

Jan 03 to Jan 04

Substance Misuse Report

Teresa Rodrigues
Substance Misuse Counsellor

Current Status

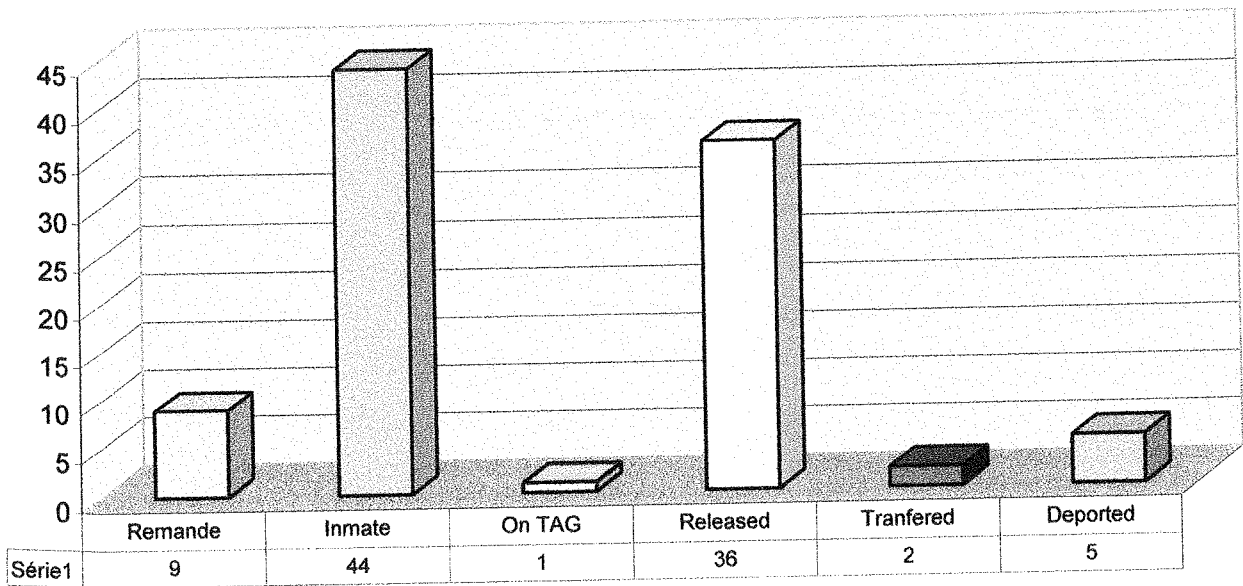

Current Status %

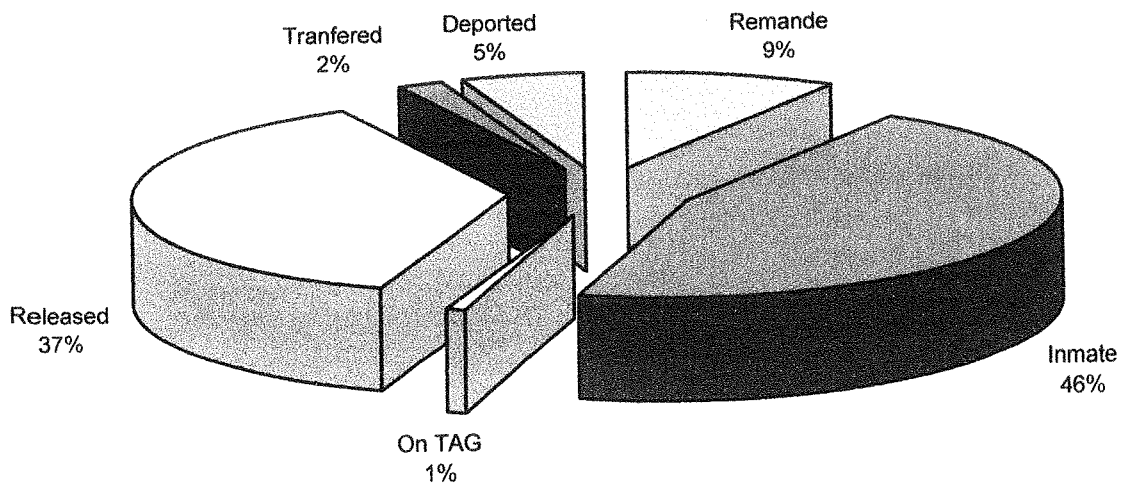

Gender

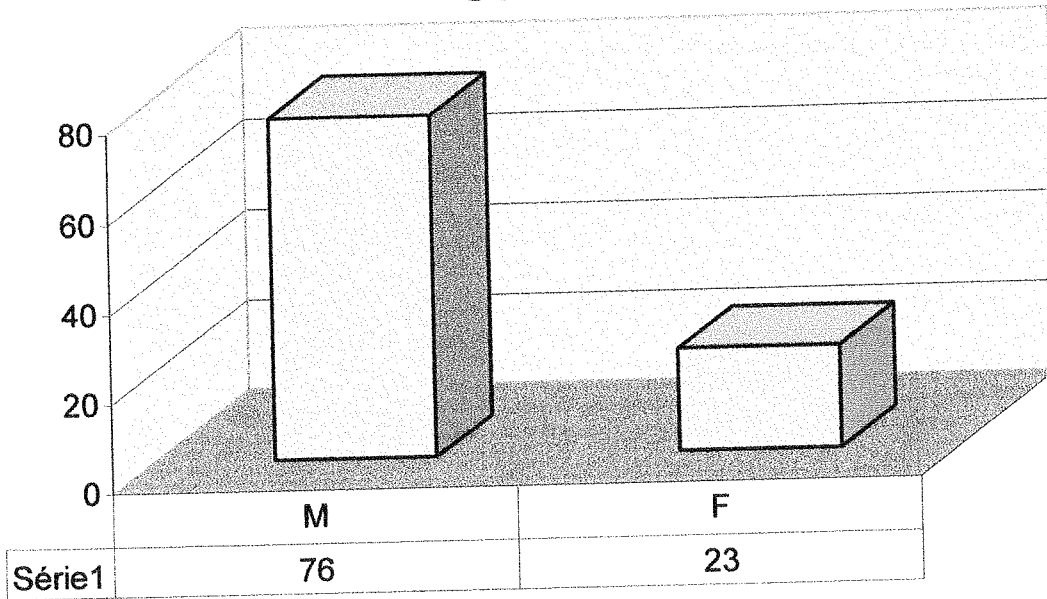

Both Female and Male, have been seen on a one to one basis, but for the moment only the female wing have weekly group work on a Thursday's.

Gender %

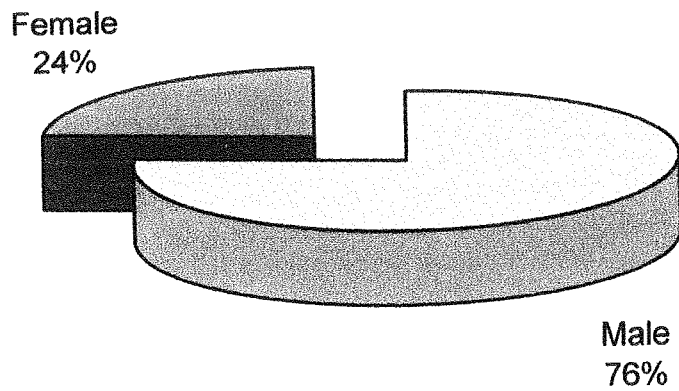

Nationality

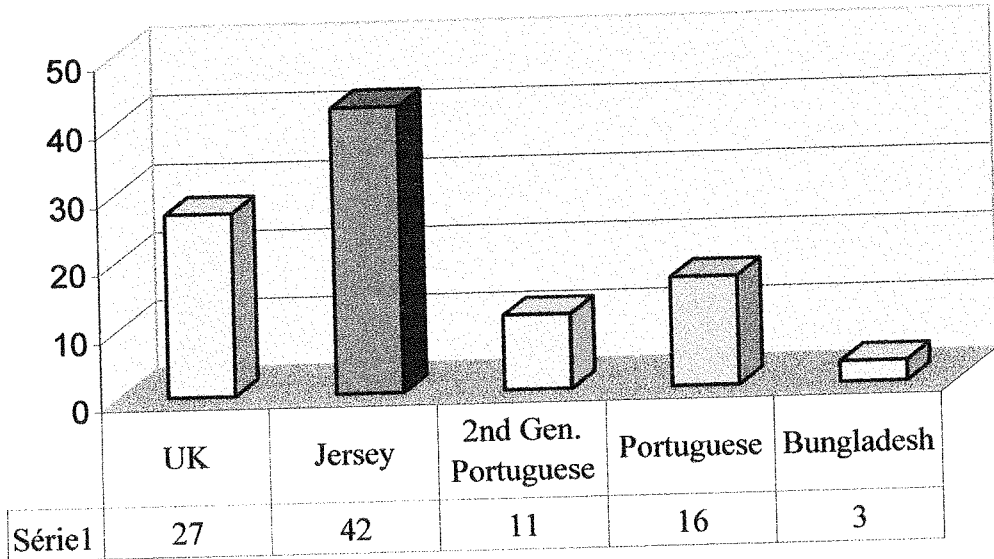

Instead of Nationalities I divided British in UK and Jersey born; The son's of Portuguese, even though they were born in Jersey I put them under 2nd generation of Portuguese.

From all of this groups the one who faces with more difficulties in relation with my work is probably the Portuguese due to the lack of education and poor communication skills (even if they speak my first language).

Nationality (%)

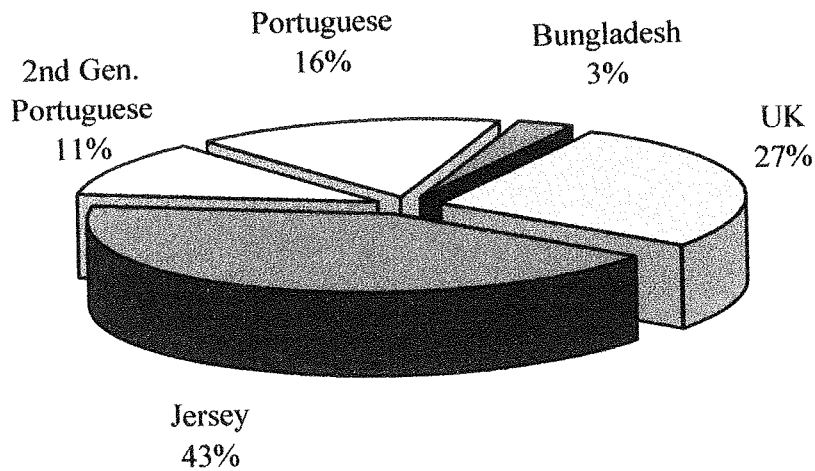

Accommodation

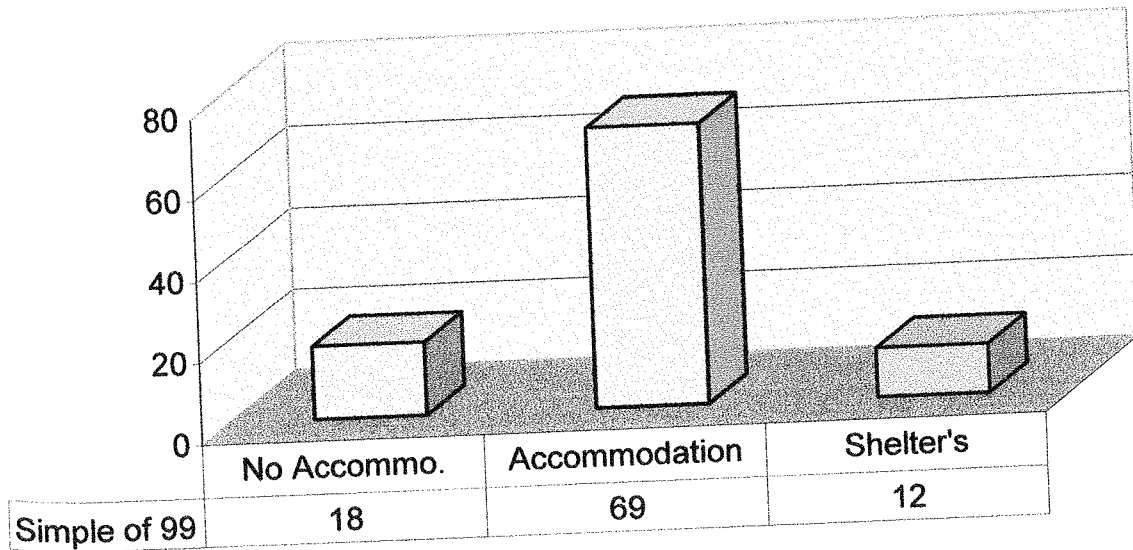

This graphic relates to accommodation after release. This area is one of the key associated with re-offenders. Even though there are 69 inmates who have accommodation, for the majority of them "Accommodation" doesn't mean that they have safe and healthy environment, some will live with partners who are still in active addiction, what will end on inmates to relapse on their first day of release. Others will go to families where the family dynamic is very "dysfunctional". 12 of them were coming from the shelter, and 19 don't have anywhere to live, and are applying for housing or shelter accommodation.

Accommodation (%)

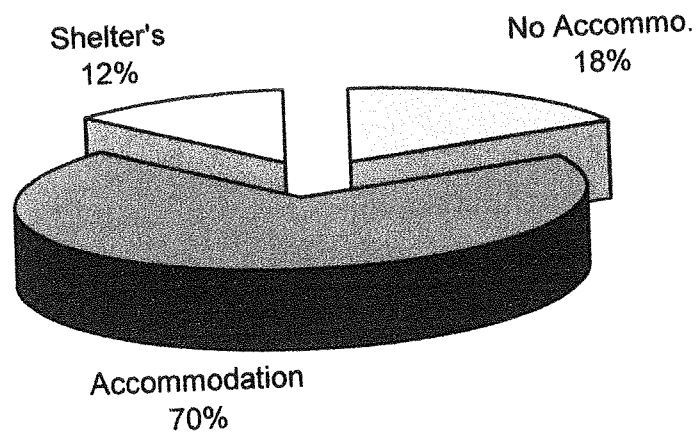

Occupation

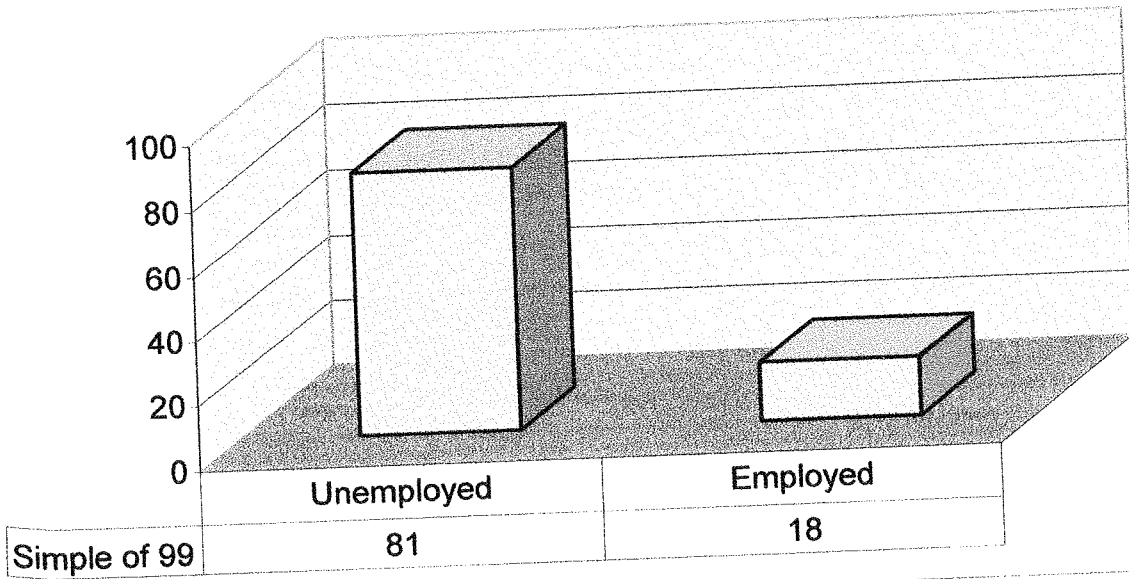

This is another relevant area for the height number of re-offenders. 82% of inmates were unemployed when their arrest, and the majority of them never worked on their life's. In this area I try to direct the work on self-efficacy, dignity and self-worth. Many of them spent their life's making money in a very short period of time, and when they leave prison they will have to deal not only with the urge of using drugs but also the urge of making "quick money", regardless the price they have to pay e.g.: prison again

Occupation (%)

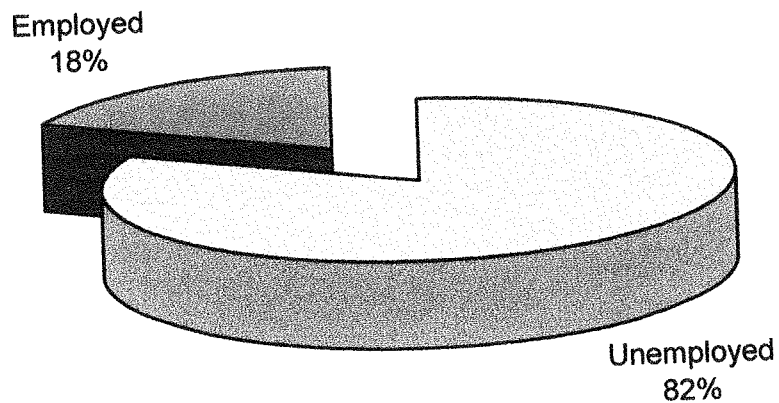

Total of the times inmates have been admitted in La Moye Prison

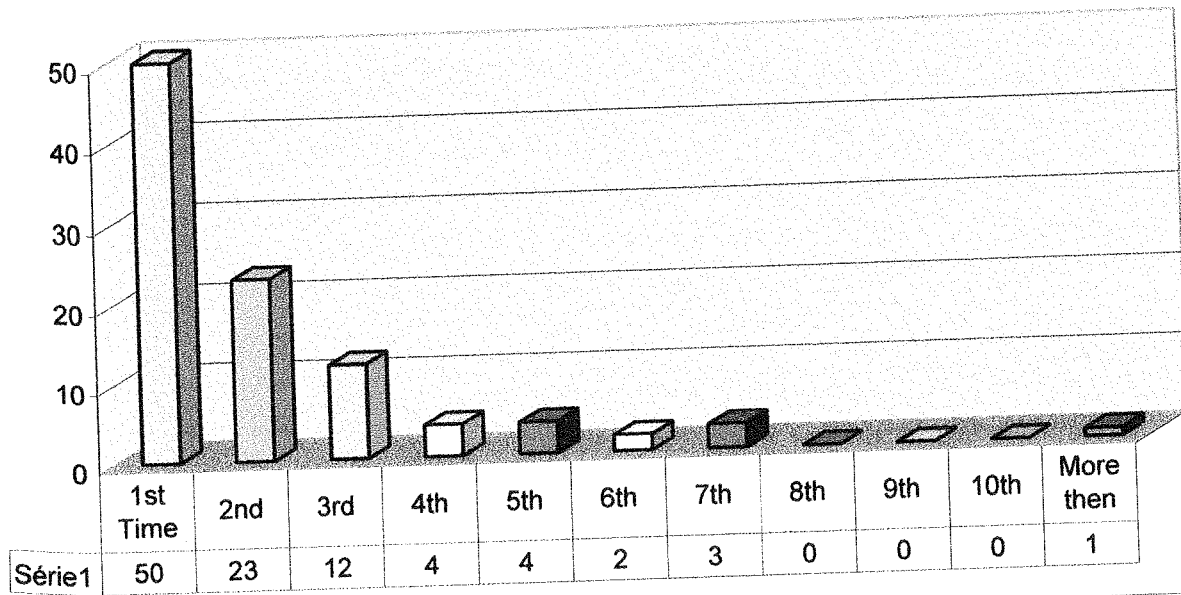

Here lays one of my goal/outcome at La Moye Prison. Lately prison is facing with major problems with overcrowded. I do believe if we address the problem of addiction and give the support to inmates to live better life's through rehabilitation we will be able to reduce the number of re-offenders and in this way to reduce the numbers in medium and long term at La Moye Prison.

Times of Arrest %

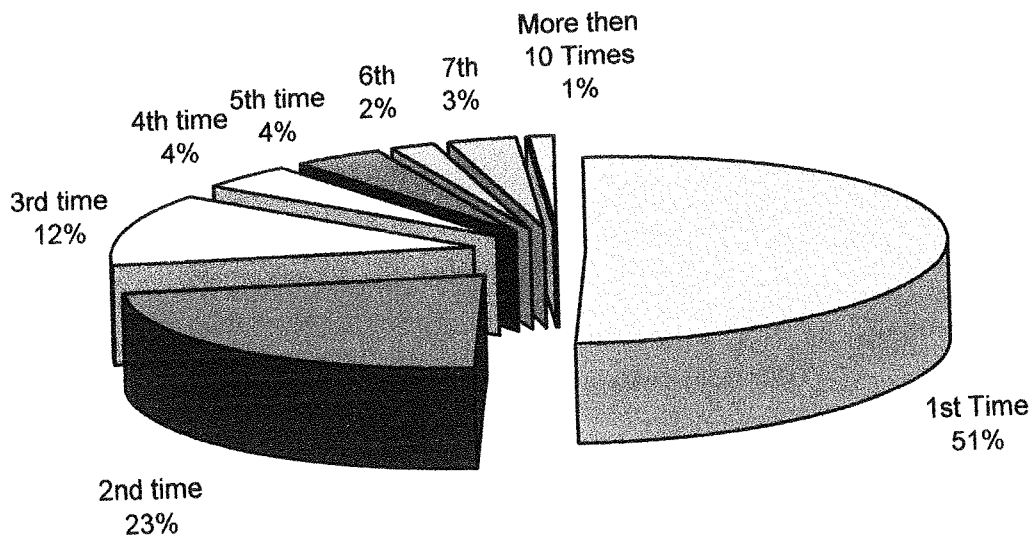

1st Drug of Choice

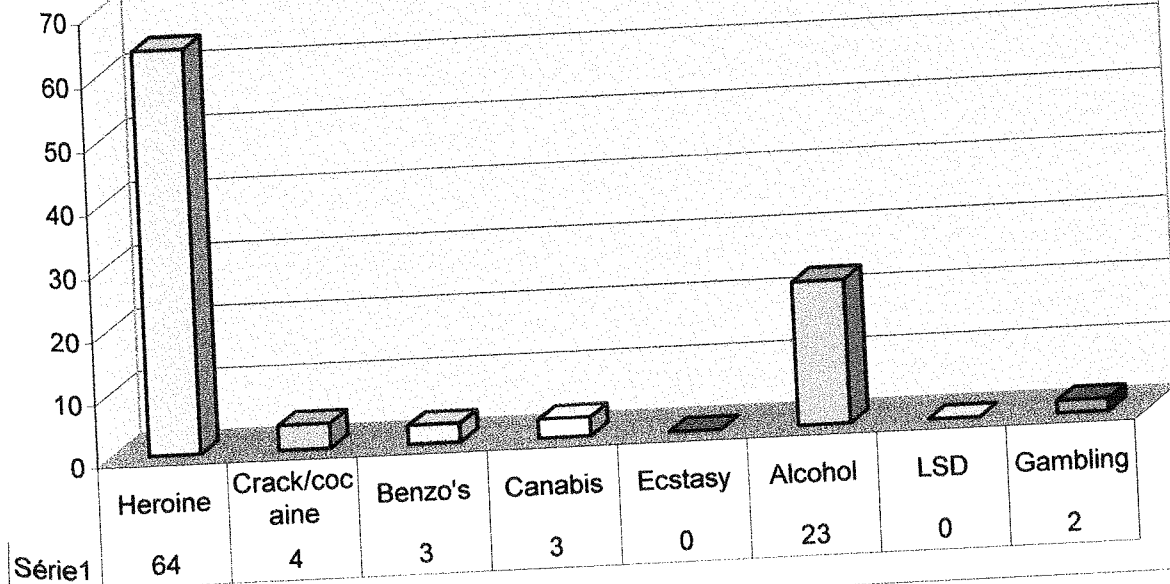

Very clearly the main drug of choice from this 99 prisoners is heroine, where probably 80% inject. All this 99, smoke tabaco.

1st Drug of Choice

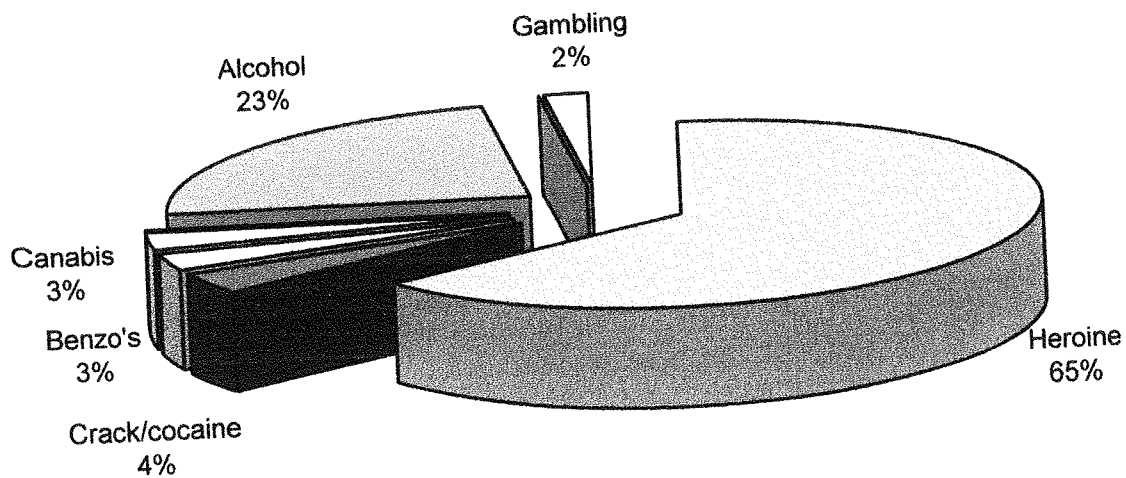

2nd Drug Of Choice

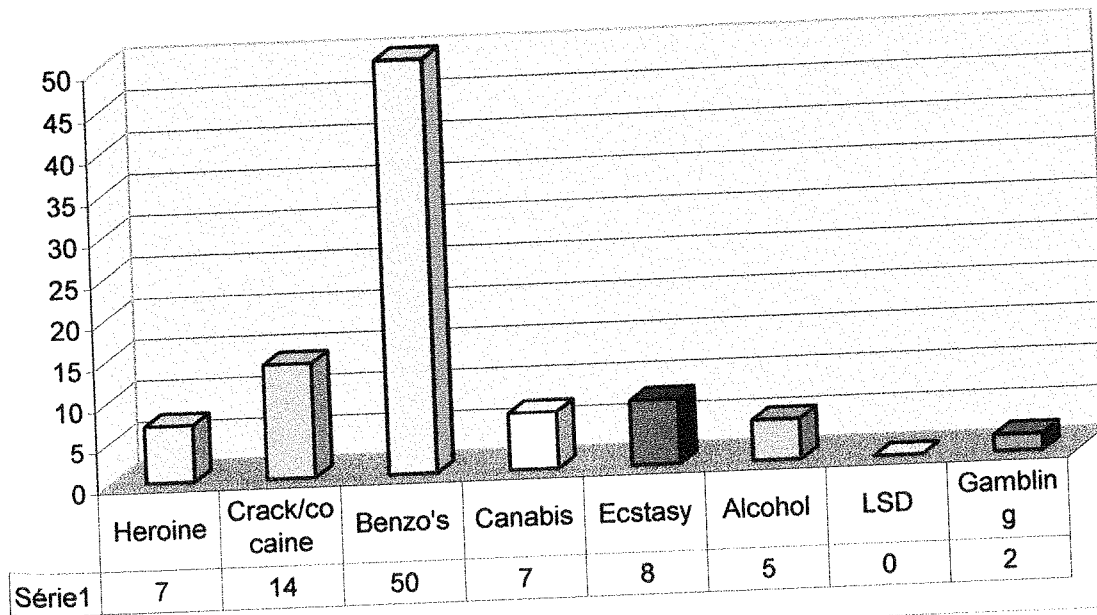

As the second drug of choice it comes the benzo's the main one is Valium and Tamazapan. They all say that heroine is so expensive and bad quality that they need to use another "downer". Crack/cocaine appears as one of the second, but this ones are the ones from the main land.

2nd Drug of Choice

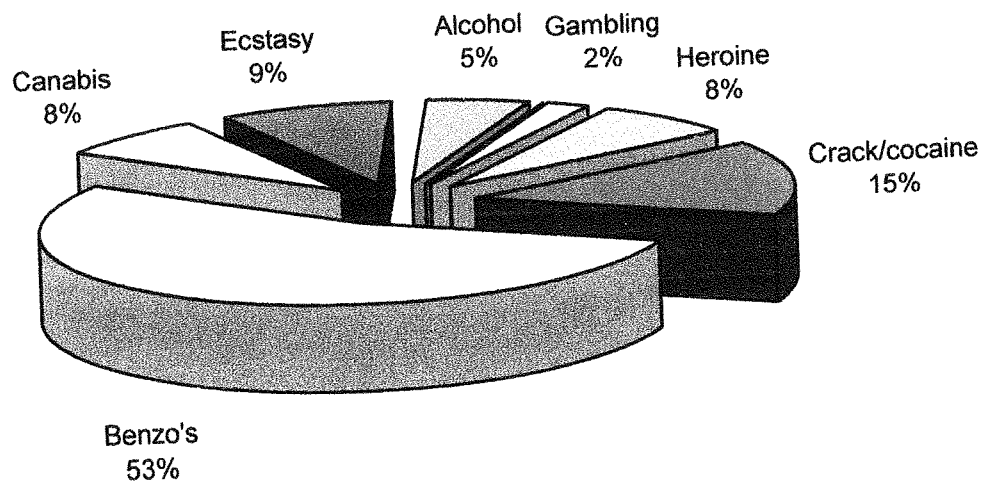

3rd Drug of Choice

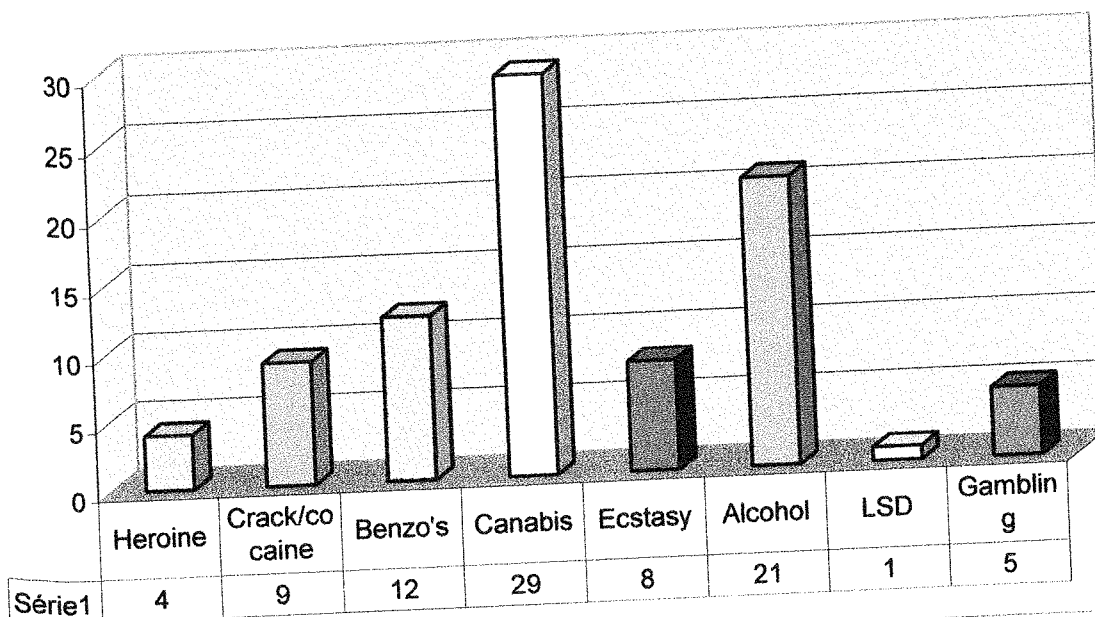

As the 3rd drug of choice it is Cannabis and alcohol, some of those who said Crack (the ones from Jersey) is not as they have much access to it but they "wish to have". Nevertheless there is an increase on Crack/cocaine in Jersey.

3rd Drug of Choice %

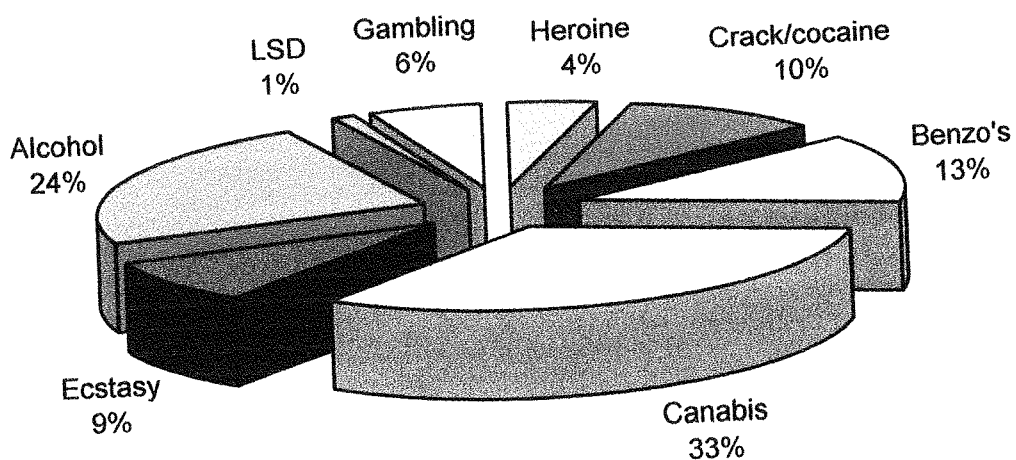

4th Drug of Choice

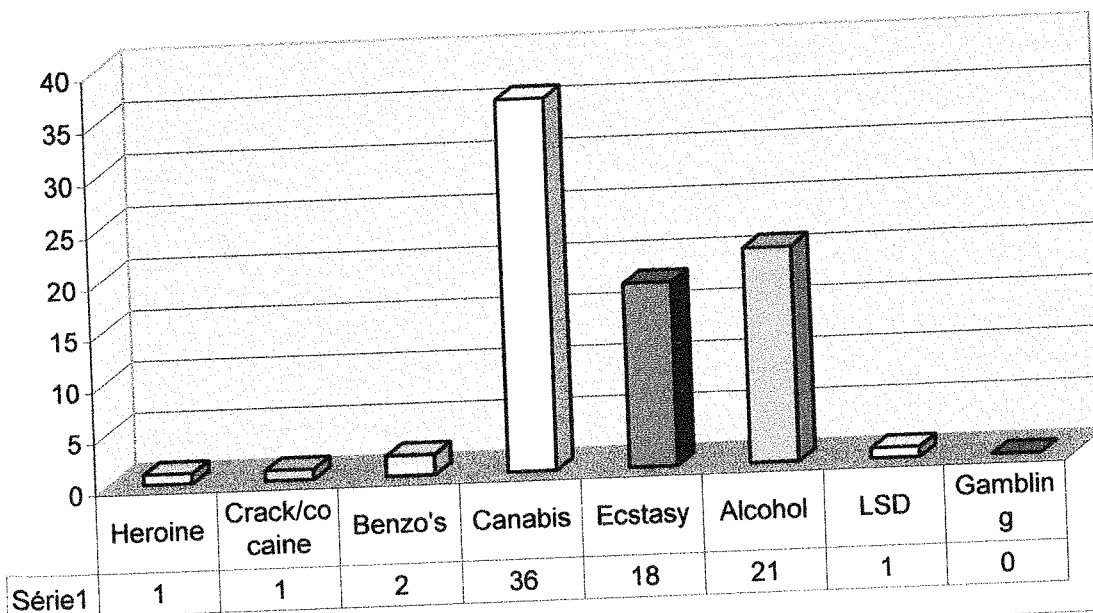

As the 4th drug of choice there is a pick on Cannabis, alcohol and Ecstasy. Eventhough Cannabis is a daily drug they never clasified as 1st Drug of choice, with alcohol there is a major denial as beeing a problem and ecstasy is a cheap recreation drug very used in Jersey.

4th Drug of Choice %

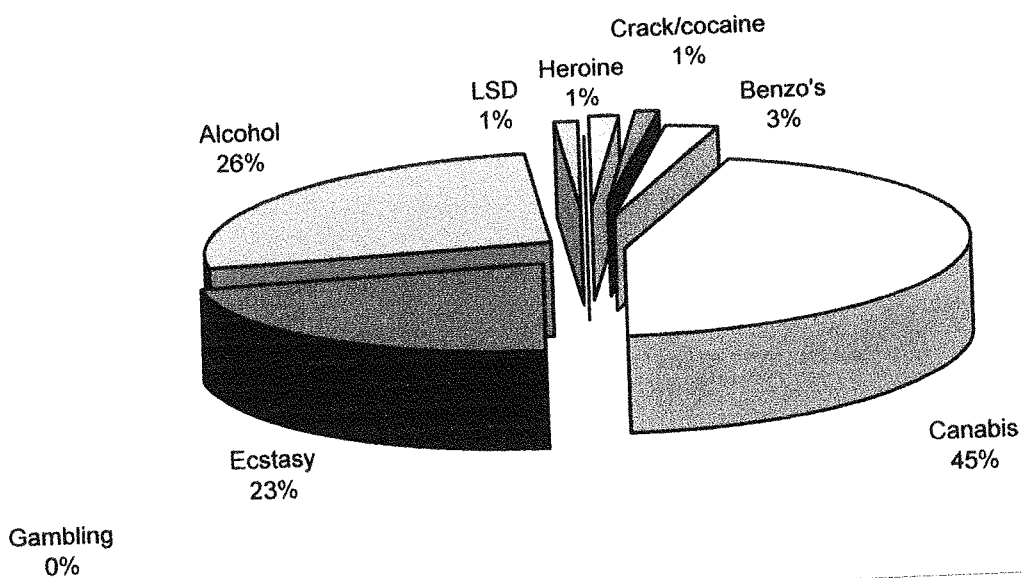

Prescribed Medication in Prison

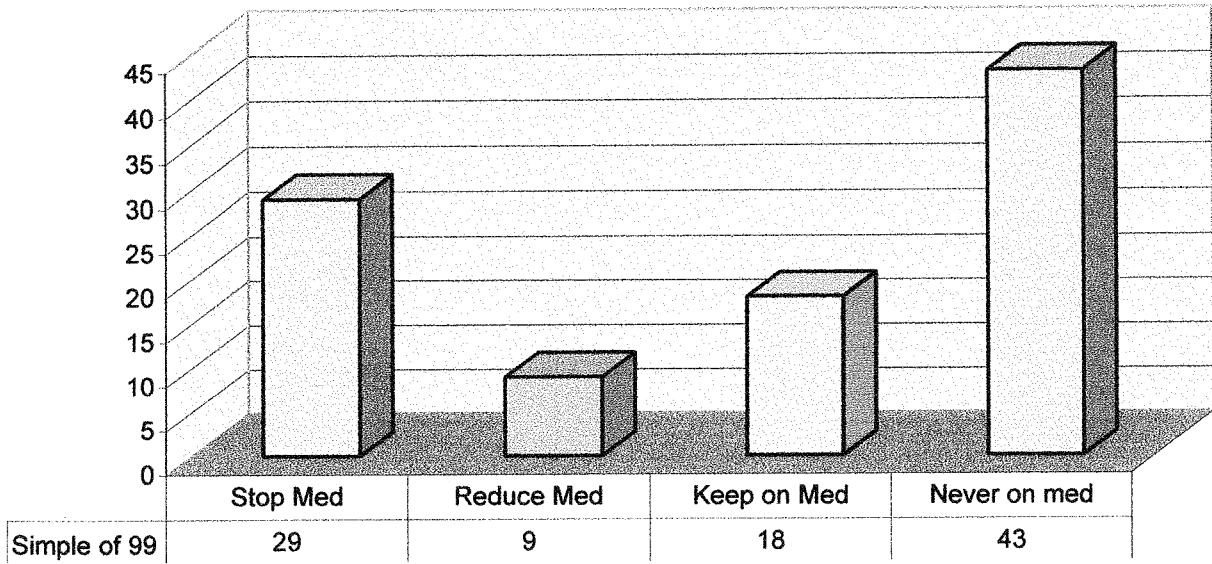

Prescribed medication in this chapter relates only to anti-depressants and tablets to help them sleep. As it can be seen on the chapter of Drug History, Benzo's is the second drug of choice for the inmates, part of my work is to try to reduce or stop the ones who are taking this medication and replace by different relaxation methods.

Prescribed Medication in Prison %

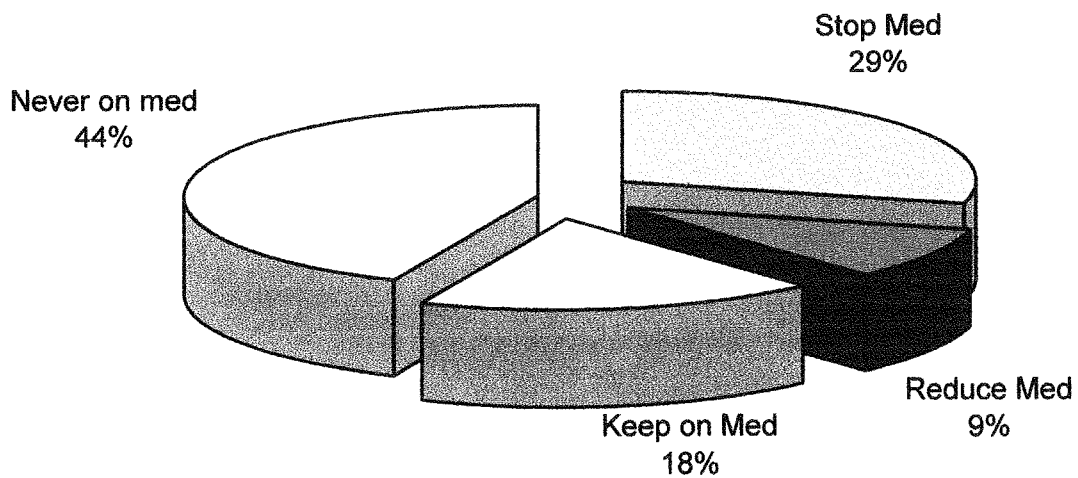

Share Paraphernalia in Prison

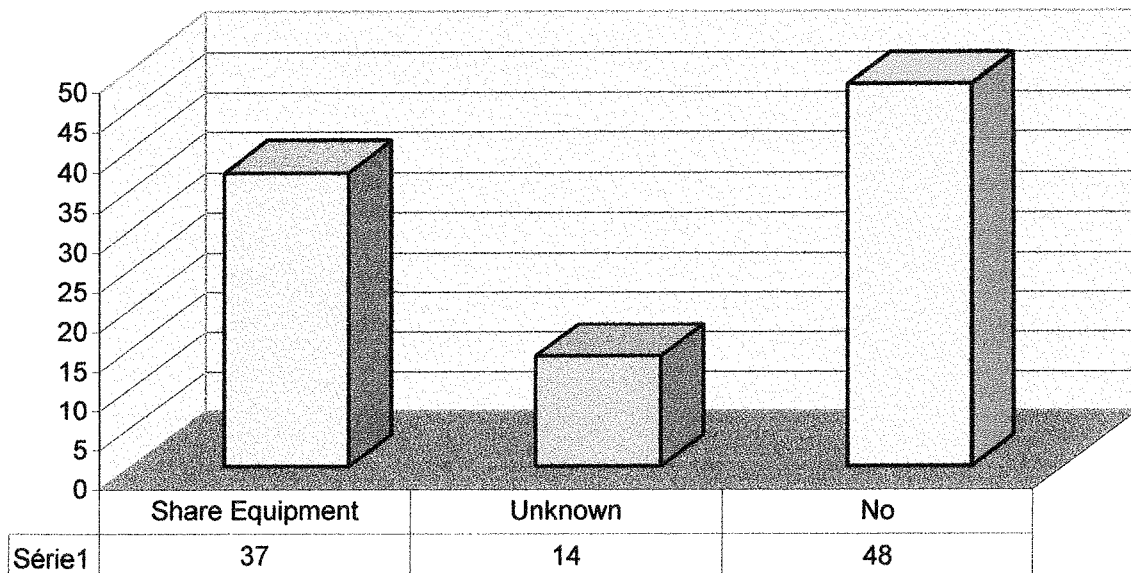

Sharing needles in prison is a big problem and it can only lead to an increase of Hepatitis C and major health problems. From the 99 users (not all heroine addicts), 37 prisoners had shared or still sharing syringes inside the prison. 14 of them didn't want to disclose that information

From the first session I have with inmates and throughout the therapeutic process I work in this important and life threatening issues, as it is the sharing of paraphernalia, mixing drugs and alcohol and the risks of overdose related with low tolerance.

Share Paraphernalia in Prison %

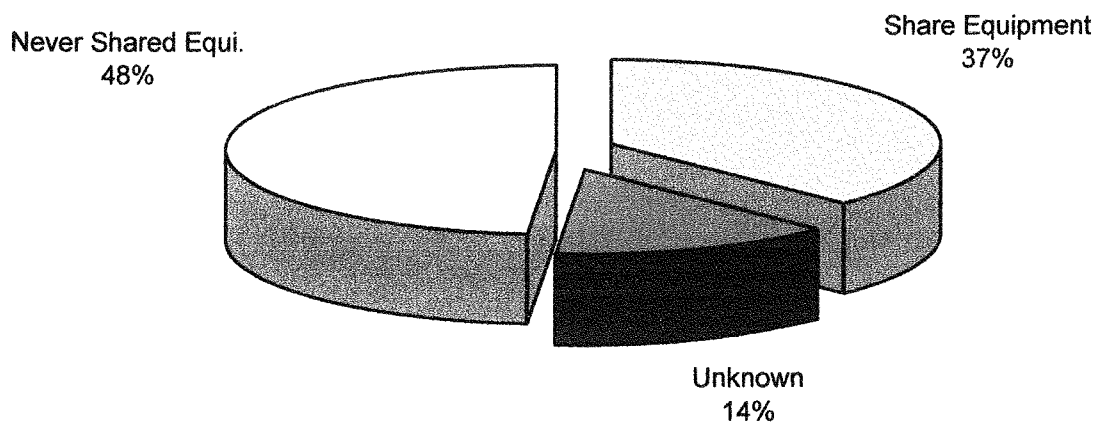

Stop Sharing equipment in Prison

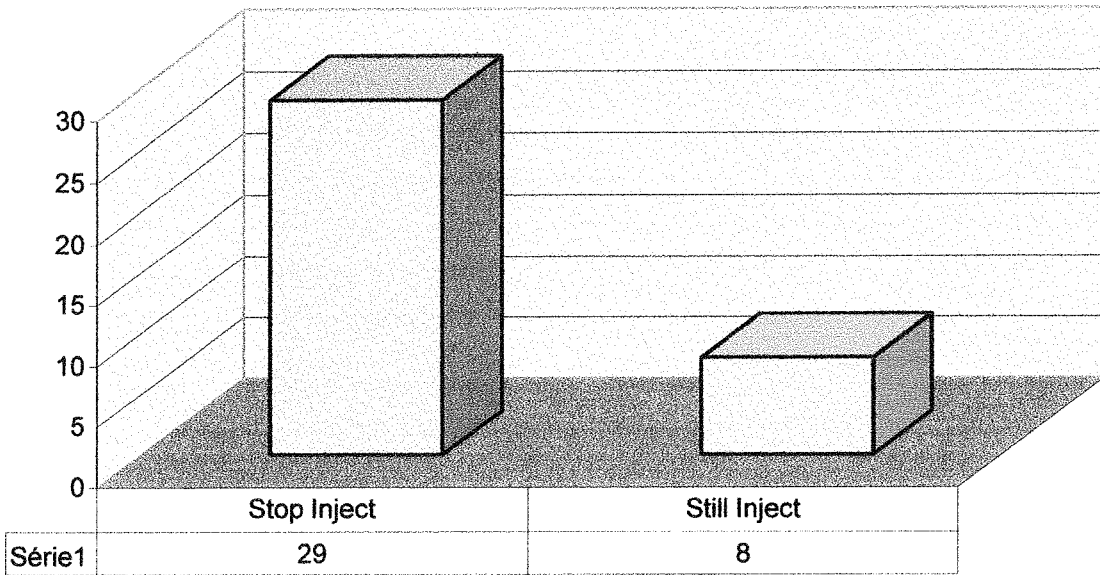

From 37 who shared syringes in prison 29 have stopped injecting, 8 are still sharing. This area have been an important work on a daily basis, on education and awareness of the risks and consequences of their using.

Stop Sharing Equipment in Prison

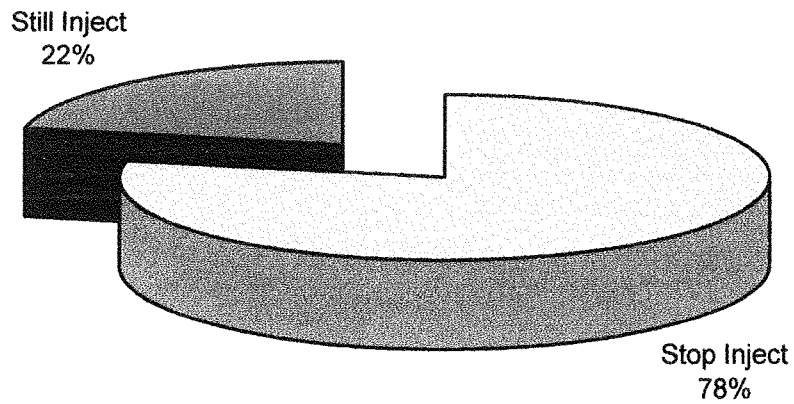

Hep C

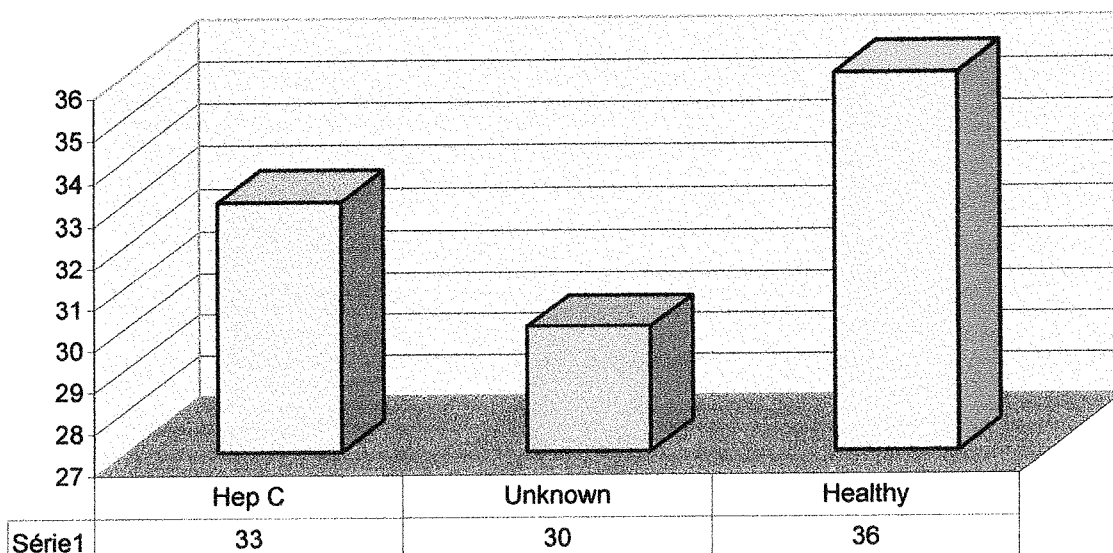

This statistics are the result of the number of inmates sharing needles. Several of them when arrived at Prison had negative hepatitis tests but on their last test it came positive. From the 99 prisoners, 33 have Hepatitis C; and 36 are clearly negative. The 30 "unknown" are the ones who are waiting for being tested (they have to wait 3 months until they put themselves in risk). Others don't want to know (hopefully, until the end of the year we will be able to persuade them to be tested).

Hep C %

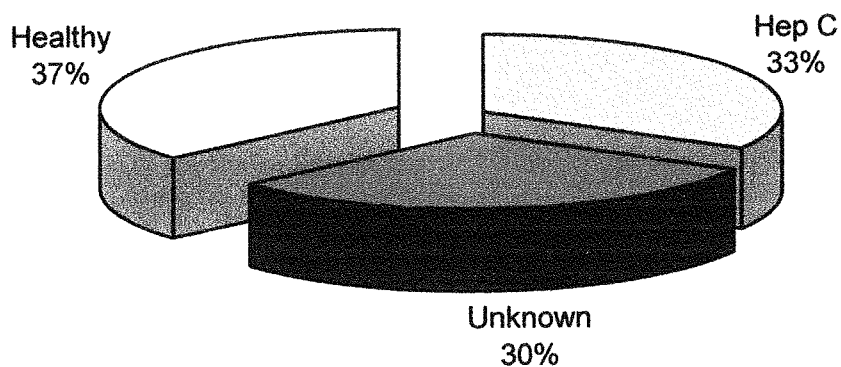

Engage on 1 to1 Counselling

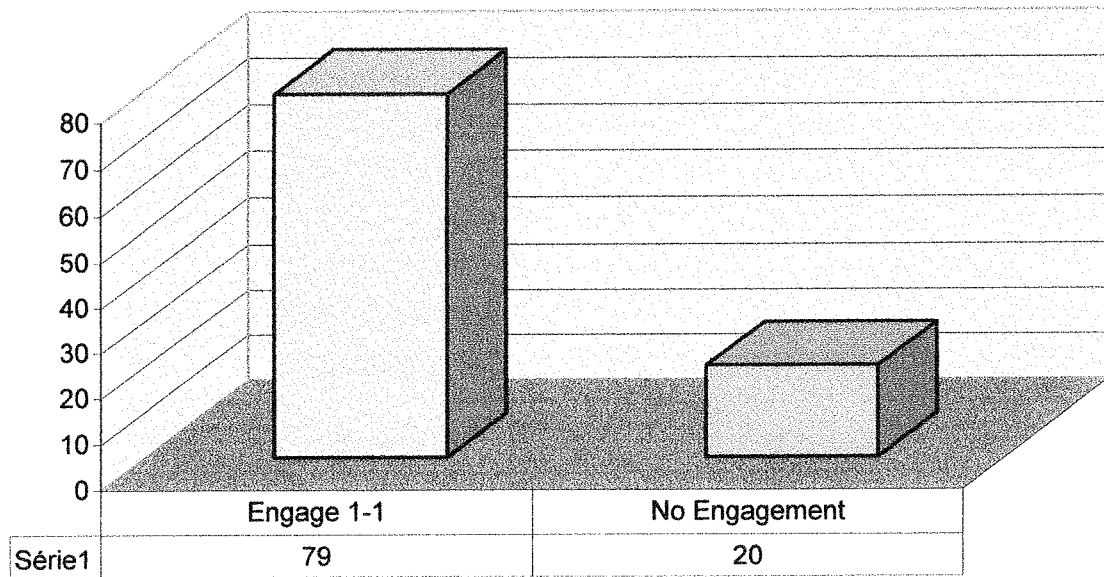

From the 99, there are 20 who didn't engage on one to one (but accepted to participate on group work and NA meetings), others were released with no time in prison for more than the assessment session.

Engage on 1 to 1 Counselling %

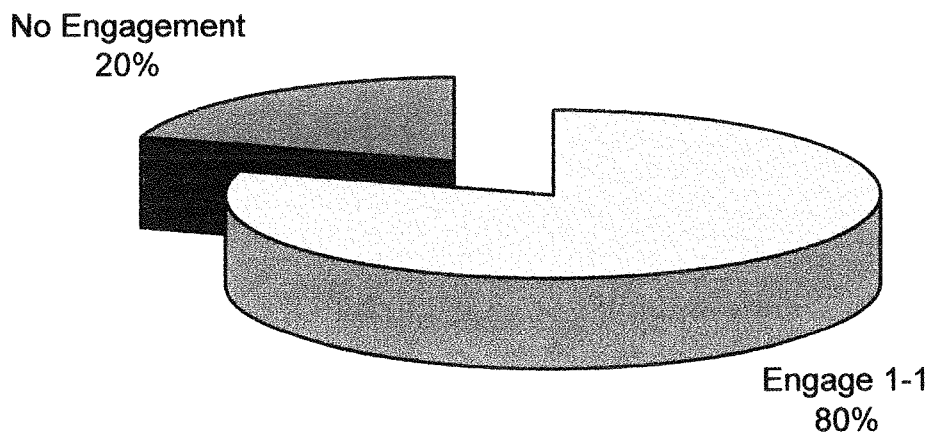

Engage on Group Work

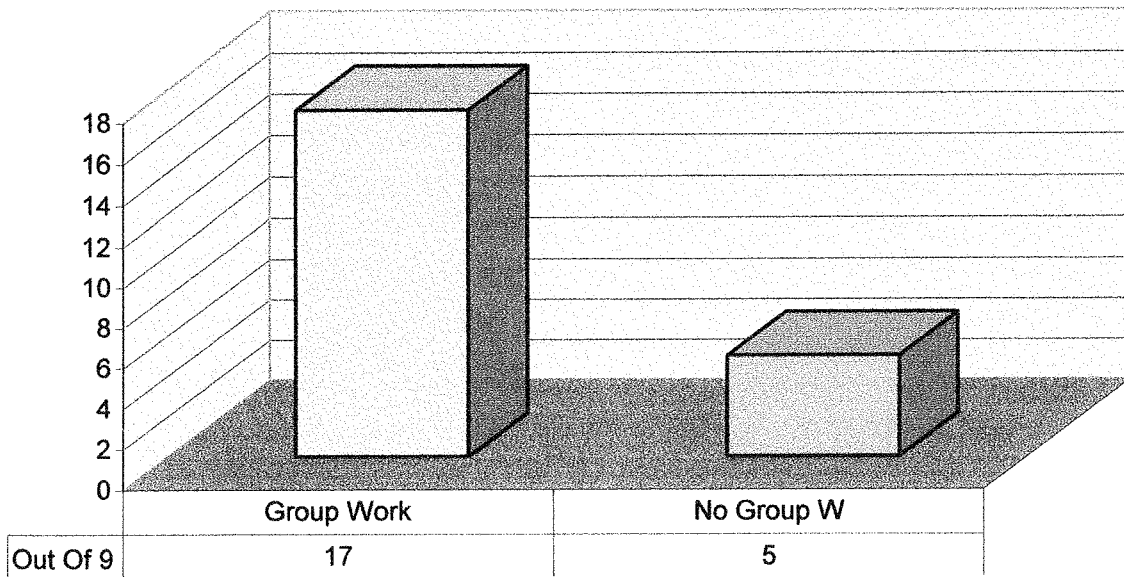

For the moment the group work is only on the Female Wing, on a weekly basis. (lectures, group therapeutic work, role play)

From 23 of the woman, 17 accept to be seen on a one-to-one and group work. there are 6 who just see me on a 1-1 basis and dont feel comfortable on group setings.

Engage on Group Work %

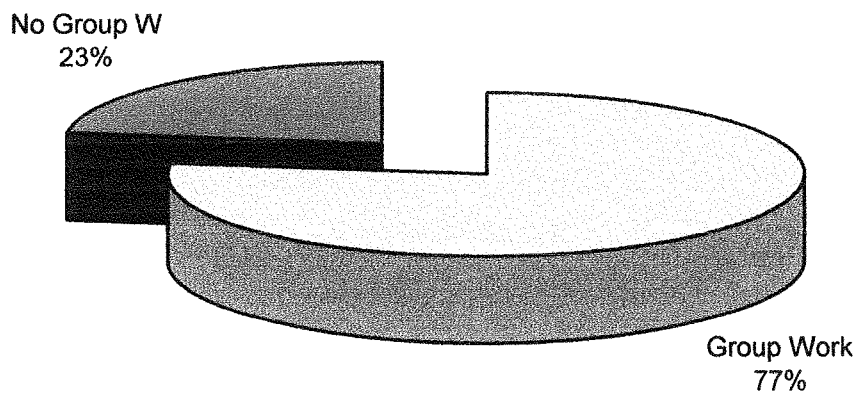

Accept Follow Up (Pos-Release)

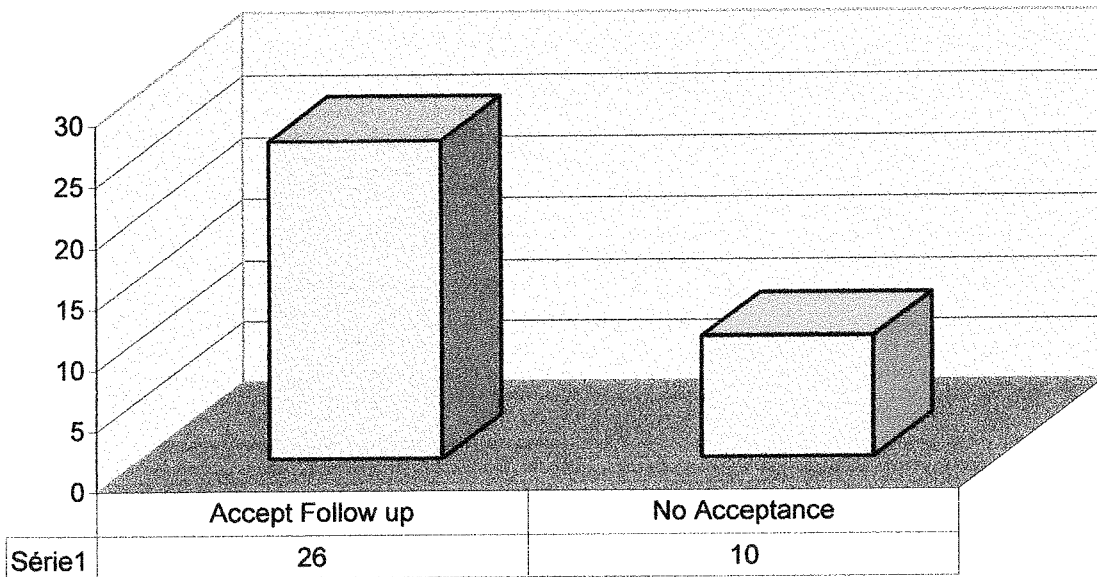

From the 36 inmates released, 26 of them accepted follow up, 7 engage on blockers while in prison. From this 36 released, only 6 re-offend.

Accept Follow Up

No Acceptance
28%

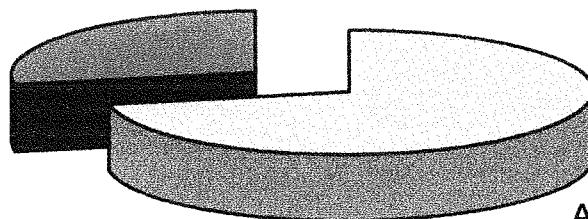

Accept Follow up
72%

Family Support

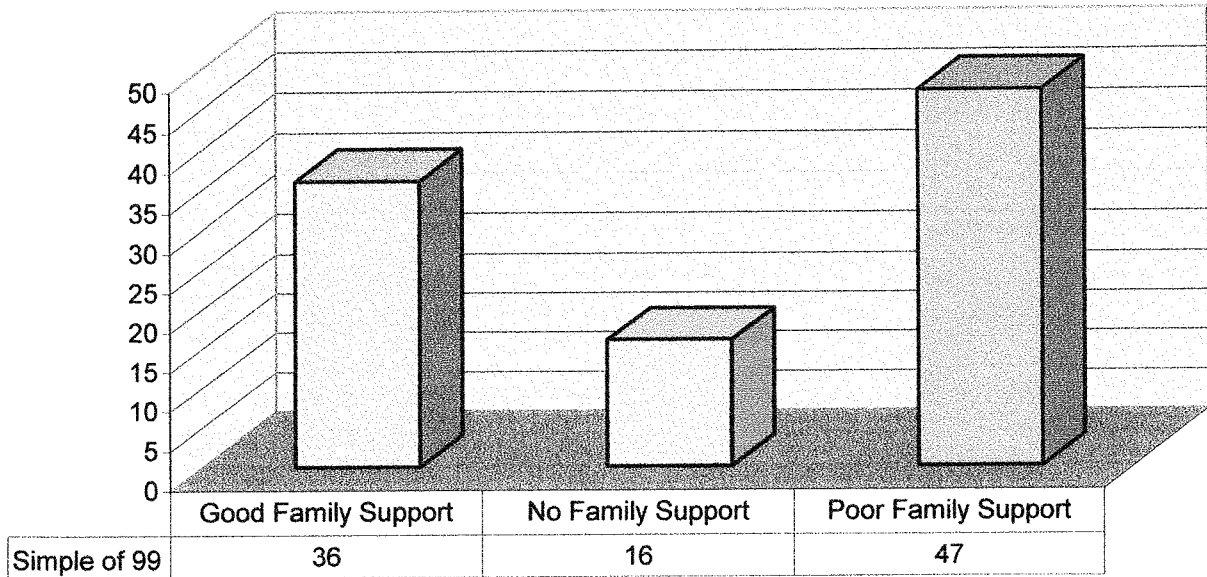

A good family support is the most desirable support that a prisoner after release should have. No family support are the ones who don't have any contacts with their families and will have to re-start their life's far away from them. Poor family support are the ones who come from a very unhealthy environment.

Family Support %

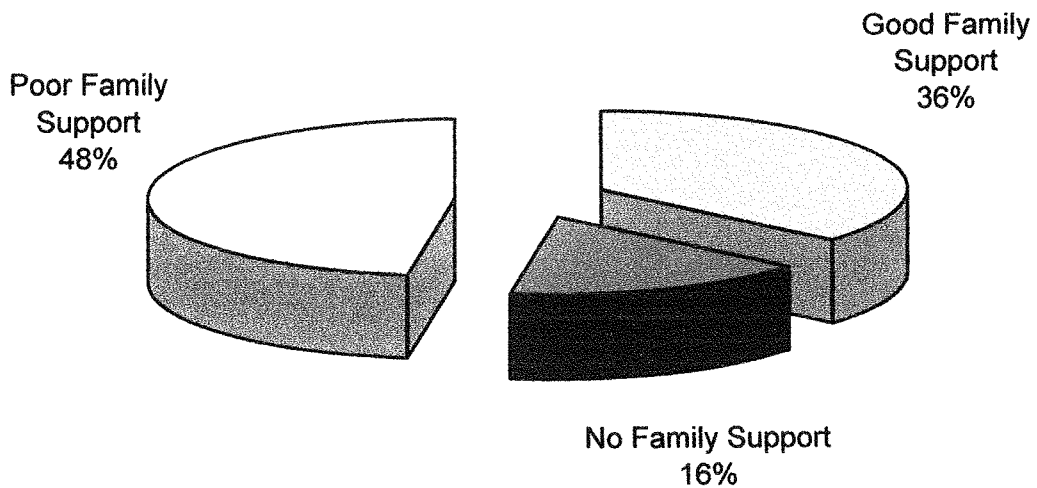

Alcohol or Drug abuse on Family Members

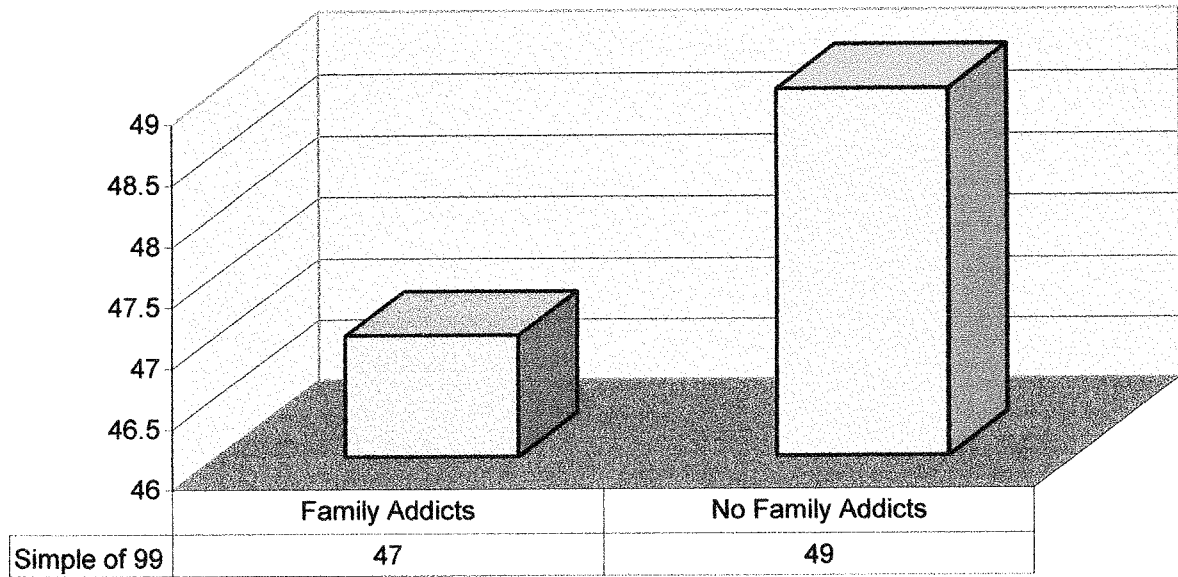

This record relates to a high risk of relapses after release. 49% of inmates have a close relative who are using drugs or have alcohol problems.

Drug & Alcohol on Family Members

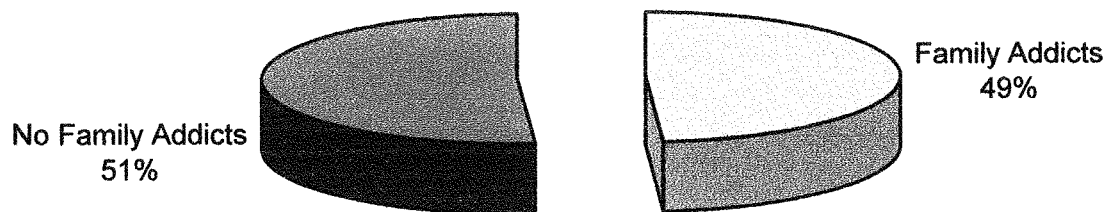

Network Support

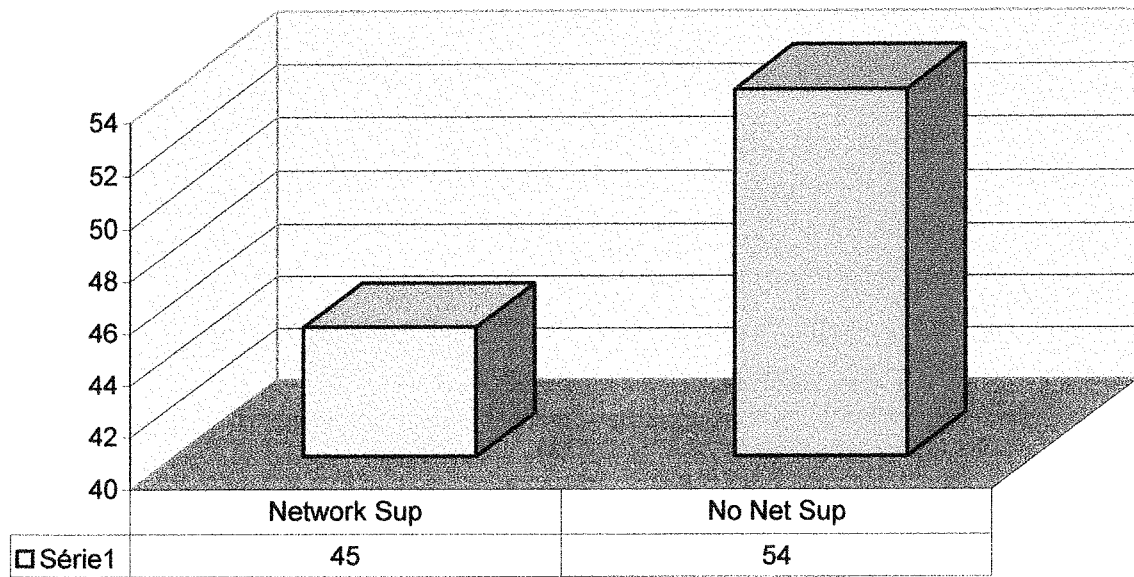

I relate Network support as an important area on their life's after release from prison, it can be a good set of friends (no drug/alcohol related), or self help groups as N.A or AA. Programmes at Probation or Drug and Alcohol Services.

Network Support

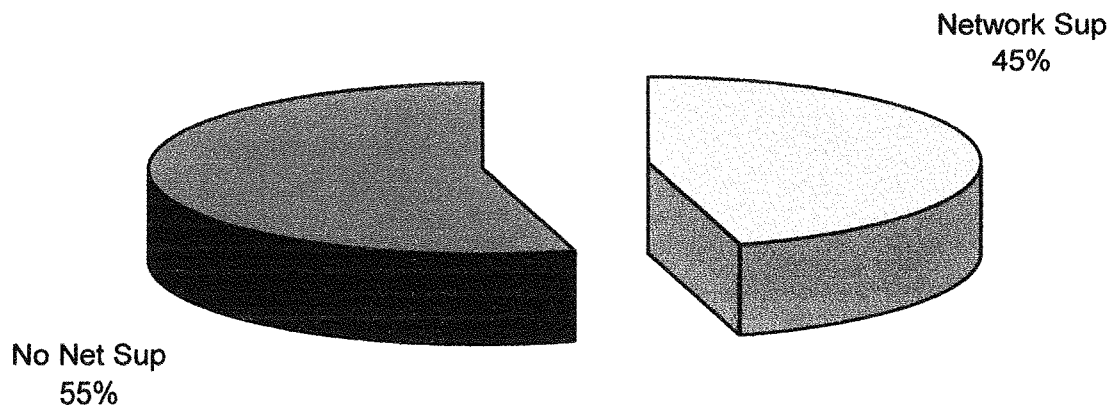

Reduction on Substance Misuse

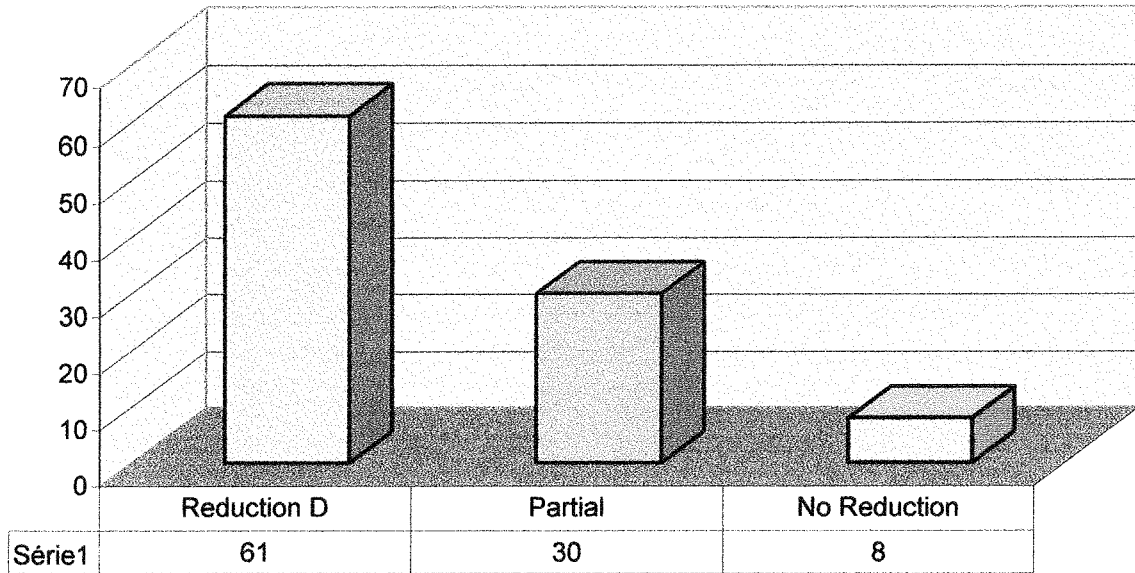

As Reduction on this graphic I meant to describe a major change on their intake. Partial are the ones who stopped with heroine but are still using other types of drug.

Reduction on Substance Misuse %

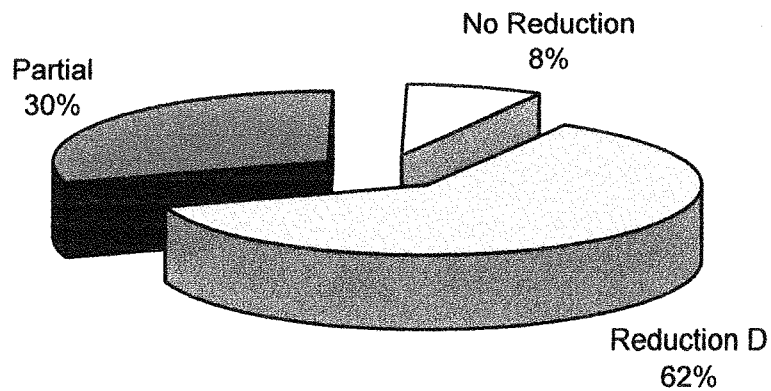

Last Positive Drug Tests

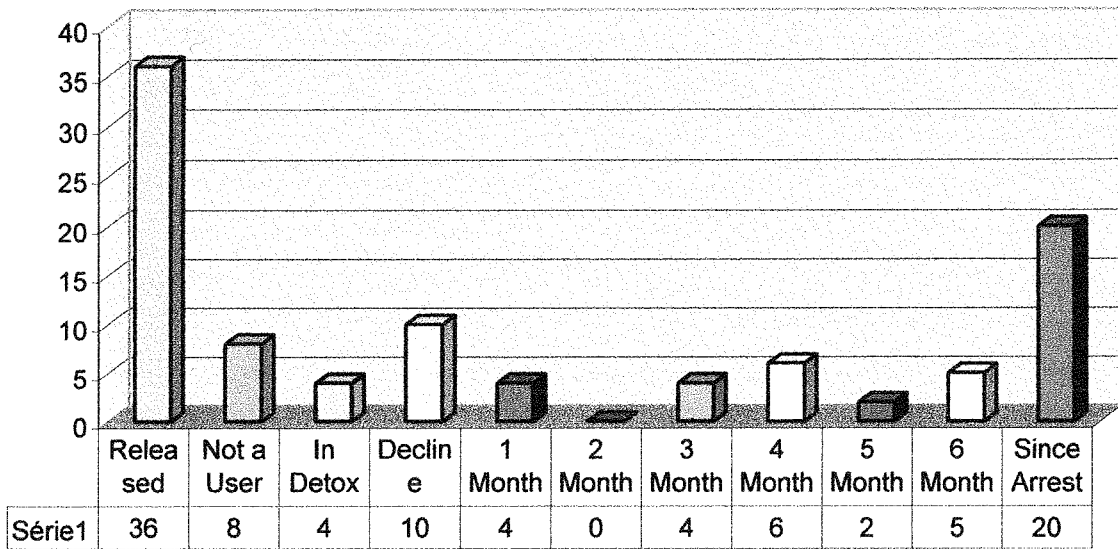

This statistics have been taken from Bomic

Last Positive Test %

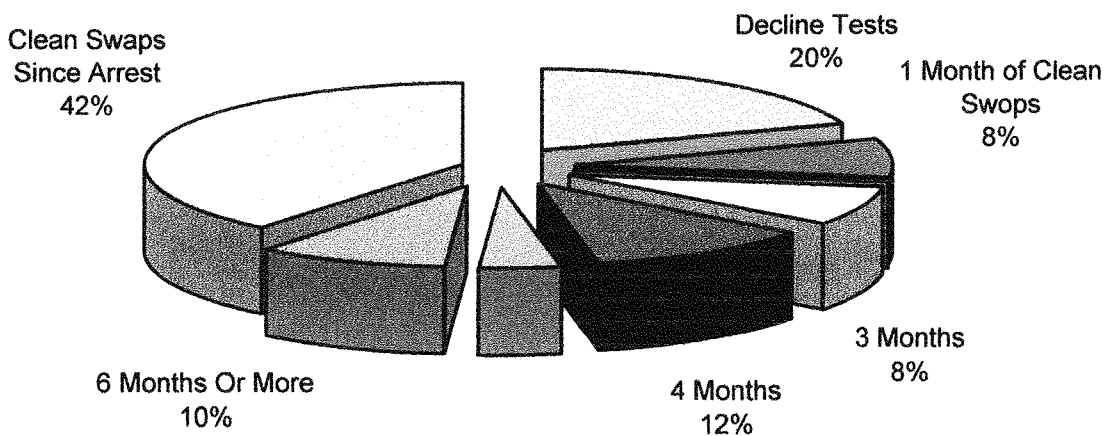

Change on Behaviour

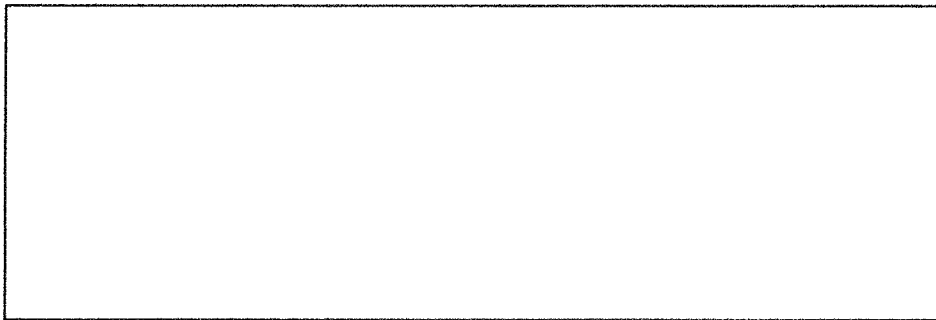
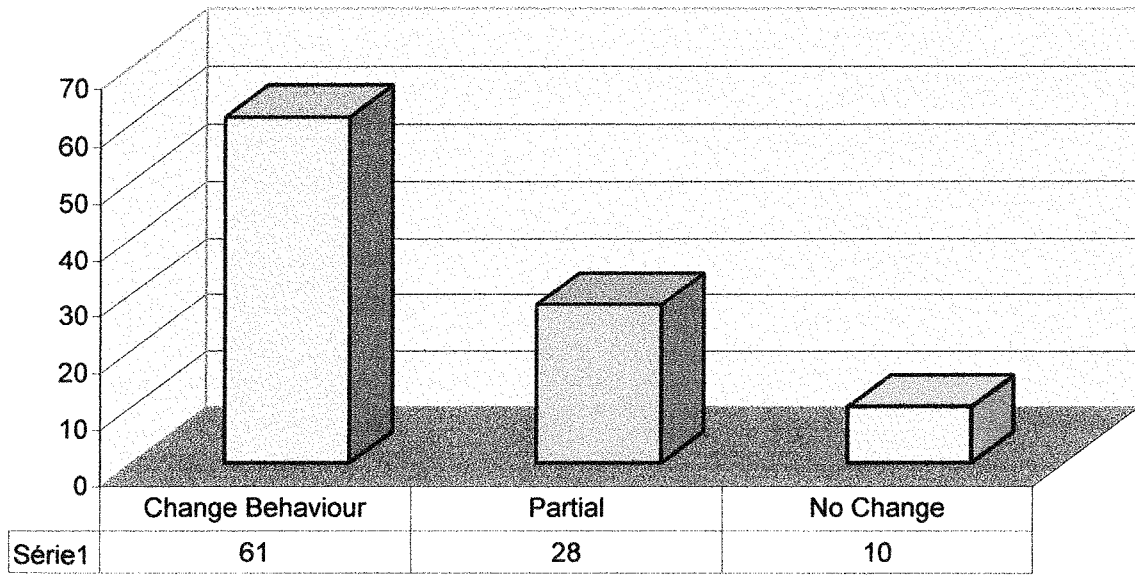

Change on Behaviour %

